

DDC-SVC-MAN-0055

# EPA04 MBE 900 Operator's Manual



13400 Outer Drive, West, Detroit, Michigan 48239-4001  
Telephone: 313-592-5000  
[www.detroitdiesel.com](http://www.detroitdiesel.com)

**Specifications are subject to change without notice. Detroit Diesel Corporation is registered to ISO 9001:2001. Copyright © Detroit Diesel Corporation. All rights reserved. Detroit Diesel Corporation is a Daimler company. Printed in U.S.A.**

---

**CALIFORNIA  
Proposition 65 Warning**

Diesel engine exhaust and some of its constituents are known to the State of California to cause cancer, birth defects, and other reproductive harm.

42824

---

## To the Operator

This manual contains instructions on the safe operation and preventive maintenance of your Detroit Diesel MBE 900 engine. Maintenance instructions cover routine engine services such as lube oil and filter changes in enough detail to permit self-servicing if desired.

The operator should become familiar with the contents of this manual before operating the engine or carrying out maintenance procedures.

Power-driven equipment is only as safe as the person operating the controls. You are urged, as the operator of this diesel engine, to keep fingers and clothing away from the revolving belts, drive shafts, etc. on engine installation.

Throughout this manual **CAUTIONS** regarding personal safety and **NOTICES** regarding engine performance or service life will appear. To avoid personal injury and ensure long engine service life, always heed these instructions.

Whenever possible, it will benefit you to rely on an authorized Detroit Diesel service outlet for all your service needs from maintenance to major parts replacement. Authorized service outlets worldwide stock factory original parts and have the specialized equipment and experienced, trained

personnel to provide prompt preventive maintenance and skilled engine repairs.

The information and specifications in this publication are based on the information in effect at the time of approval for printing. Contact an authorized Detroit Diesel service outlet for information on the latest revision. The right is reserved to make changes at any time without obligation.

### NOTICE:

Coolant must be inhibited with the recommended Supplemental Coolant Additives (SCA) listed in this manual. In addition, the engine can be equipped with a coolant filter/inhibitor system as an installed option or as an after-sale item. Failure to check and maintain SCA levels at required concentrations will result in severe damage corrosion to the engine cooling system and related components.

## Trademark Information

Detroit Diesel®, DDEC®, and Diagnostic Link® are registered trademarks of Detroit Diesel Corporation. Nexiq™ is a trademark of Nexiq Technologies, Inc. All other trademarks are the property of their respective owners.



# TABLE OF CONTENTS

<b>CAUTION SUMMARY</b> .....	1
ENGINE OPERATION .....	1
PREVENTIVE MAINTENANCE .....	2
ELECTRICAL SYSTEM .....	4
COOLING SYSTEM .....	5
AIR INTAKE SYSTEM .....	5
FUEL SYSTEM .....	7
COMPRESSED AIR .....	8
LUBRICATING OIL AND FILTERS .....	8
<b>IDENTIFICATION</b> .....	9
PERSONNEL REQUIREMENTS .....	12
ENGINE CONVERSIONS AND MODIFICATIONS .....	13
GENERAL VIEW OF THE MBE900 ENGINE .....	13
ENGINE IDENTIFICATION NUMBER .....	20
DESCRIPTION OF THE ENGINE .....	21
EXHAUST GAS RECIRCULATION .....	22
EXHAUST BRAKE/CONSTANT-THROTTLE VALVES, OPTIONAL .....	23
ELECTRONIC ENGINE CONTROL SYSTEM .....	24
DDEC-ECU .....	25
DDEC-VCU .....	26
SENSOR LOCATIONS .....	27
<b>OPERATION</b> .....	30
BEFORE STARTING THE ENGINE .....	30
CHECKING THE BATTERIES .....	30
CHECKING THE OIL LEVEL .....	31
CHECKING THE COOLANT LEVEL (COLD CHECK) .....	32
ADDING FUEL .....	32
PRIMING THE FUEL SYSTEM .....	32
STARTING THE ENGINE .....	32
CHECKING THE COOLANT LEVEL (HOT CHECK) .....	33
STARTING AN ENGINE THAT HAS NOT BEEN RUN FOR AN EXTENDED PERIOD .....	34

TABLE OF CONTENTS

---

MONITORING ENGINE OPERATION .....	35
BATTERY CHARGE .....	35
OIL PRESSURE .....	35
EXCESSIVE IDLING .....	36
CHANGING THE IDLE SPEED .....	36
SHUTTING DOWN THE ENGINE .....	36
SHUTTING DOWN AFTER HARD OPERATION .....	36
EMERGENCY RUNNING MODE .....	37
STOP ENGINE OVERRIDE OPTION .....	37
COLD WEATHER OPERATION .....	38
WINTER FRONTS .....	38
<b>CLEANING AND STORAGE .....</b>	<b>39</b>
CLEANING THE ENGINE .....	39
HIGH-PRESSURE CLEANING EQUIPMENT .....	39
CLEANING THE COOLING SYSTEM .....	39
DEGREASING .....	40
STORAGE .....	41
<b>TROUBLESHOOTING .....</b>	<b>42</b>
EMERGENCY STARTING .....	42
TROUBLESHOOTING THE ELECTRONIC ENGINE CONTROL SYSTEM .....	42
GENERAL TROUBLESHOOTING .....	42
<b>SERVICE PRODUCTS .....</b>	<b>55</b>
DIESEL FUELS .....	55
FLOW IMPROVERS .....	55
KEROSENE .....	55
ENGINE OILS .....	56
EGR ENGINES .....	56
NON-EGR ENGINES .....	57
SYNTHETIC OILS .....	57
COOLANT .....	57
FULLY-FORMULATED ANTIFREEZE .....	57
WATER .....	58
COOLANT SPECIFICATIONS .....	58
COOLANT CONCENTRATION .....	58

SUPPLEMENTAL COOLANT ADDITIVES FOR FULLY FORMULATED COOLANT .....	59
DROPOUT .....	60
DISPOSAL .....	60
COLD WEATHER PRODUCTS .....	60
WINTER-GRADE DIESEL FUEL .....	60
LOW-VISCOSITY ENGINE OIL .....	61
WINTER COOLANT ANTIFREEZE PROTECTION .....	61
BATTERIES .....	61
<b>TECHNICAL DATA</b> .....	63
ENGINE DATA FOR EGR ENGINE .....	64
ENGINE DATA FOR NON-EGR ENGINE .....	65
TESTING AND ADJUSTING VALUES .....	66
<b>MAINTENANCE</b> .....	67
SCHEDULED INTERVALS .....	67
MAINTENANCE SCHEDULE TYPES .....	67
SEVERE SERVICE .....	67
SHORT-HAUL .....	68
LONG-HAUL .....	68
OPERATING HOURS VS. FUEL CONSUMPTION (OIL DRAIN INTERVAL ONLY) .....	68
UNIMOG .....	68
MAINTENANCE SCHEDULE AND INTERVAL OPERATIONS .....	68
MAINTENANCE INTERVALS .....	68
MAINTENANCE OPERATION SETS .....	69
SCHEDULE USE .....	69
MAINTENANCE TABLES AND GRAPHS .....	70
REQUIRED MAINTENANCE OPERATIONS .....	78
ENGINE INSPECTING .....	78
VALVE LASH CHECKING AND ADJUSTING .....	78
GAINING ACCESS TO THE VALVES .....	79
METHOD ONE: ADJUST EACH CYLINDER IN FIRING ORDER .....	80
METHOD TWO: ADJUST ALL VALVES USING TWO CRANKSHAFT POSITIONS .....	81
CHECKING VALVE LASH .....	82

TABLE OF CONTENTS

---

ADJUSTING VALVE LASH .....	82
RESTORING THE VEHICLE TO OPERATING CONDITION ..	83
FUEL PREFILTER ELEMENT CLEANING .....	83
MAIN FUEL FILTER ELEMENT CHANGING .....	85
ENGINE OIL AND FILTER CHANGING .....	86
OIL CENTRIFUGE .....	89
COOLANT CONCENTRATION CHECKING .....	90
COOLANT FLUSHING AND CHANGING .....	91
COOLING SYSTEM INSPECTING .....	93
<b>CUSTOMER ASSISTANCE .....</b>	<b>94</b>
WORKING WITH DDC SERVICE OUTLETS .....	98
STEP ONE .....	98
STEP TWO .....	98
STEP THREE .....	99
<b>LIMITED WARRANTY ON NEW DETROIT DIESEL MBE 900 ENGINES USED IN ON-HIGHWAY VEHICLE APPLICATIONS .....</b>	<b>100</b>
TERMS OF COVERAGE .....	100
USES .....	100
DEFECTS .....	100
REPAIRS .....	100
WARRANTY PERIOD .....	100
LIKE REPLACEMENT ENGINE .....	101
SERVICE SUPPLIES .....	101
ENGINE REMOVAL AND REINSTALLATION .....	101
THIS WARRANTY DOES NOT COVER: .....	101
REPAIRS DUE TO ACCIDENTS, MISUSE, STORAGE DAMAGE, NEGLIGENCE OR CERTAIN MODIFICATIONS .....	101
MAINTENANCE .....	102
INCIDENTAL OR CONSEQUENTIAL DAMAGES .....	102
OTHER LIMITATIONS .....	102
<b>LIMITED WARRANTY ON NEW DETROIT DIESEL MBE 900 ENGINES USED IN SCHOOL BUS APPLICATIONS .....</b>	<b>103</b>
TERMS OF COVERAGE .....	103
USES .....	103
DEFECTS .....	103
REPAIRS .....	103



WARRANTY PERIOD .....	103
SERVICE SUPPLIES .....	104
LIKE REPLACEMENT ENGINE .....	104
ENGINE REMOVAL AND REINSTALLATION .....	104
THIS WARRANTY DOES NOT COVER: .....	104
REPAIRS DUE TO ACCIDENTS, MISUSE, STORAGE DAMAGE, NEGLIGENCE OR CERTAIN MODIFICATIONS .....	104
MAINTENANCE .....	105
INCIDENTAL OR CONSEQUENTIAL DAMAGES .....	105
OTHER LIMITATIONS .....	105

**LIMITED WARRANTY ON NEW DETROIT DIESEL MBE  
900 ENGINES USED IN FIRE TRUCK OR CRASH VEHICLE**

<b>APPLICATIONS</b> .....	106
TERMS OF COVERAGE .....	106
USES .....	106
DEFECTS .....	106
REPAIRS .....	106
WARRANTY PERIOD .....	106
LIKE REPLACEMENT ENGINE .....	107
SERVICE SUPPLIES .....	107
ENGINE REMOVAL AND REINSTALLATION .....	107
THIS WARRANTY DOES NOT COVER: .....	107
REPAIRS DUE TO ACCIDENTS, MISUSE, STORAGE DAMAGE, NEGLIGENCE OR CERTAIN MODIFICATIONS .....	107
MAINTENANCE .....	108
INCIDENTAL OR CONSEQUENTIAL DAMAGES .....	108
OTHER LIMITATIONS .....	108

**LIMITED WARRANTY ON NEW DETROIT DIESEL MBE 900  
ENGINES USED IN UNIMOG APPLICATIONS**

<b>TERMS OF COVERAGE</b> .....	109
USES .....	109
DEFECTS .....	109
REPAIRS .....	109
WARRANTY PERIOD .....	109
LIKE REPLACEMENT ENGINE .....	110
SERVICE SUPPLIES .....	110
ENGINE REMOVAL AND REINSTALLATION .....	110

*TABLE OF CONTENTS*

---

THIS WARRANTY DOES NOT COVER: ..... 110  
REPAIRS DUE TO ACCIDENTS, MISUSE, STORAGE DAMAGE,  
NEGLIGENCE OR CERTAIN MODIFICATIONS ..... 110  
MAINTENANCE ..... 111  
INCIDENTAL OR CONSEQUENTIAL DAMAGES ..... 111  
OTHER LIMITATIONS ..... 111

## CAUTION SUMMARY

The following cautions must be observed by the operator of the vehicle or equipment in which this engine is installed and/or by those performing basic engine preventive maintenance. Failure to read and heed these cautions and exercise reasonable care for personal safety and the safety of others when operating the vehicle/equipment or performing basic engine preventive maintenance may result in personal injury and engine and/or vehicle/equipment damage.

### Engine Operation

Observe the following cautions when operating the engine.

 <b>WARNING:</b> <b>FIRE</b>
<p><b>To avoid injury from fire, keep all potential ignition sources away from diesel fuel, including open flames, sparks, and electrical resistance heating elements. Do not smoke when refueling.</b></p>

 <b>WARNING:</b> <b>PERSONAL INJURY</b>
<p><b>Diesel engine exhaust and some of its constituents are known to the State of California to cause cancer, birth defects, and other reproductive harm.</b></p> <ul style="list-style-type: none"> <li><input type="checkbox"/> <b>Always start and operate an engine in a well ventilated area.</b></li> <li><input type="checkbox"/> <b>If operating an engine in an enclosed area, vent the exhaust to the outside.</b></li> <li><input type="checkbox"/> <b>Do not modify or tamper with the exhaust system or emission control system.</b></li> </ul>

## Preventive Maintenance

Observe the following cautions when performing preventative maintenance.



### **WARNING:**

#### **HOT OIL**

To avoid injury from hot oil, do not operate the engine with the rocker cover(s) removed.



### **WARNING:**

#### **PERSONAL INJURY**

To avoid injury from slipping and falling, immediately clean up any spilled liquids.



### **CAUTION:**

#### **USED ENGINE OIL**

To avoid injury to skin from contact with the contaminants in used engine oil, wear protective gloves and apron.



### **WARNING:**

#### **PERSONAL INJURY**

To avoid injury when working near or on an operating engine equipped with an hydraulic clutch fan, remove loose items of clothing and jewelry. Tie back or contain long hair that could be caught in any moving part causing injury. The hydraulic fan may start without warning.



### **WARNING:**

#### **HOT COOLANT**

To avoid scalding from the expulsion of hot coolant, never remove the cooling system pressure cap while the engine is at operating temperature. Wear adequate protective clothing (face shield, rubber gloves, apron, and boots). Remove the cap slowly to relieve pressure.



**WARNING:**  
**PERSONAL INJURY**

To avoid injury from the projection of tools or other objects that may fall on or behind the vibration damper of an engine, always check and remove these items before starting the engine.



**WARNING:**  
**FIRE**

To avoid injury from combustion of heated lubricating-oil vapors, stop the engine immediately if an oil leak is detected.



**WARNING:**  
**PERSONAL INJURY**

To avoid injury from contact with rotating parts when an engine is operating with the air inlet piping removed, install an air inlet screen shield over the turbocharger air inlet. The shield prevents contact with rotating parts.



**WARNING:**  
**FIRE**

To avoid injury from fire, do not smoke or allow open flames when working on an operating engine.



**WARNING:**  
**FIRE**

To avoid injury from fire from a buildup of volatile vapors, keep the engine area well ventilated during operation.



**WARNING:**  
**PERSONAL INJURY**

To avoid injury when using caustic cleaning agents, follow the chemical manufacturers usage, disposal, and safety instructions.

## Electrical System

Observe the following cautions when jump starting an engine, charging a battery, or working with the vehicle electrical system.



### **WARNING:** PERSONAL INJURY

To avoid injury from accidental engine startup while servicing the engine, disconnect/disable the starting system.



### **CAUTION:** Electrical Shock

To avoid injury from electrical shock, use care when connecting battery cables. The magnetic switch studs are at battery voltage.



### **WARNING:** Battery Explosion and Acid Burn

To avoid injury from battery explosion or contact with battery acid, work in a well ventilated area, wear protective clothing, and avoid sparks or flames near the battery. If you come in contact with battery acid:

- Flush your skin with water.
- Apply baking soda or lime to help neutralize the acid.
- Flush your eyes with water.
- Get medical attention immediately.



### **WARNING:** ELECTRICAL SHOCK

To avoid injury from electrical shock, do not touch battery terminals, alternator terminals, or wiring cables while the engine is operating.

## Cooling System

Observe the following cautions when servicing the cooling system.

 <b>WARNING:</b> <b>HOT COOLANT</b>
To avoid scalding from the expulsion of hot coolant, never remove the cooling system pressure cap while the engine is at operating temperature. Wear adequate protective clothing (face shield, rubber gloves, apron, and boots). Remove the cap slowly to relieve pressure.

## Air Intake System

Observe the following cautions when working on the air intake system.

 <b>WARNING:</b> <b>PERSONAL INJURY</b>
To avoid injury from hot surfaces, wear protective gloves, or allow engine to cool before removing any component.

 <b>WARNING:</b> <b>PERSONAL INJURY</b>
To avoid injury from slipping and falling, immediately clean up any spilled liquids.



**WARNING:**  
**PERSONAL INJURY**

To avoid injury from contact with rotating parts when an engine is operating with the air inlet piping removed, install an air inlet screen shield over the turbocharger air inlet. The shield prevents contact with rotating parts.





## Fuel System

Observe the following cautions when fueling the vehicle or working with the fuel system.

 <b>CAUTION:</b> <b>PERSONAL INJURY</b>
<p>To avoid injury from fuel spills, do not overfill the fuel tank.</p>

 <b>WARNING:</b> <b>FIRE</b>
<p>To avoid injury from fire, contain and eliminate leaks of flammable fluids as they occur. Failure to eliminate leaks could result in fire.</p>

 <b>WARNING:</b> <b>FIRE</b>
<p>To avoid injury from fire, keep all potential ignition sources away from diesel fuel, including open flames, sparks, and electrical resistance heating elements. Do not smoke when refueling.</p>

 <b>WARNING:</b> <b>FIRE</b>
<p><b>To avoid injury from fire caused by heated diesel-fuel vapors:</b></p> <ul style="list-style-type: none"> <li><input type="checkbox"/> Keep those people who are not directly involved in servicing away from the engine.</li> <li><input type="checkbox"/> Stop the engine immediately if a fuel leak is detected.</li> <li><input type="checkbox"/> Do not smoke or allow open flames when working on an operating engine.</li> <li><input type="checkbox"/> Wear adequate protective clothing (face shield, insulated gloves and apron, etc.).</li> <li><input type="checkbox"/> To prevent a buildup of potentially volatile vapors, keep the engine area well ventilated during operation.</li> </ul>

## Compressed Air

Observe the following cautions when using compressed air.

 **WARNING:**  
EYE INJURY

To avoid injury from flying debris when using compressed air, wear adequate eye protection (face shield or safety goggles) and do not exceed 276 kPa (40 psi) air pressure.

 **WARNING:**  
FIRE

To avoid injury from fire, do not smoke or allow open flames when working on an operating engine.

 **WARNING:**  
FIRE

To avoid injury from fire from a buildup of volatile vapors, keep the engine area well ventilated during operation.

## Lubricating Oil and Filters

Observe the following cautions when replacing the engine lubricating oil and filters.

 **WARNING:**  
PERSONAL INJURY

To avoid injury from slipping and falling, immediately clean up any spilled liquids.

 **WARNING:**  
FIRE

To avoid injury from combustion of heated lubricating-oil vapors, stop the engine immediately if an oil leak is detected.

## IDENTIFICATION

The MBE900 engine is built in accordance with sound technological principles and based on state-of-the-art technology. It complies with all United States Environmental Protection Agency (USEPA) and California Air Resources Board (CARB) emission

standards. An emission label is attached to the cylinder head cover, as required by law. See Figure 1 for the emission label for the 6-cylinder EGR model and Figure 2 for the 4-cylinder EGR model.

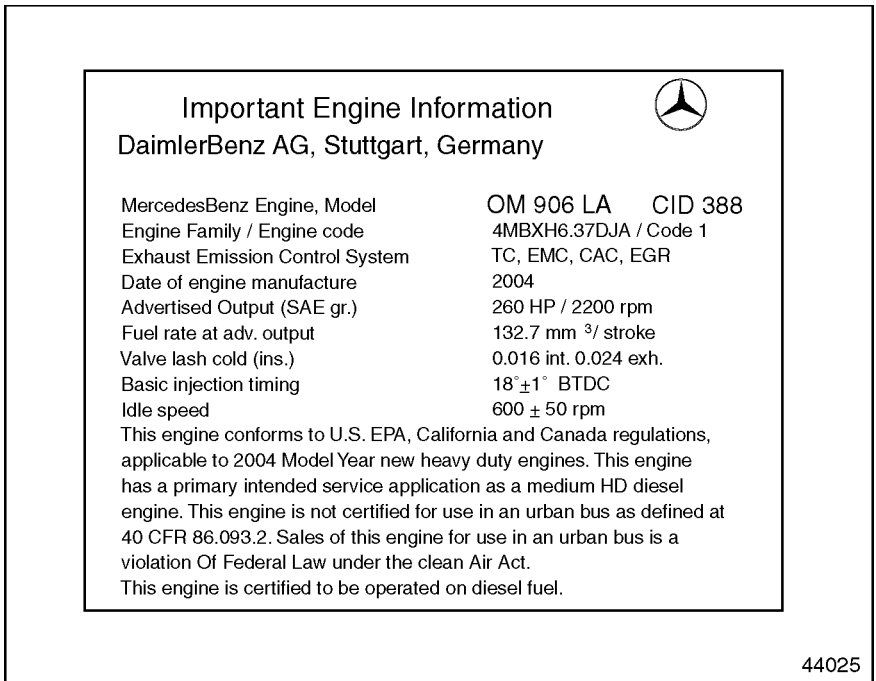



Figure 1 Emission Label, 6-Cylinder EGR Engine

### Important Engine Information

DaimlerBenz AG, Stuttgart, Germany



MercedesBenz Engine, Model	OM 904 LA	CID 259
Engine Family / Engine code	4MBXH4.25DJA / Code 1	
Exhaust Emission Control System	TC;EMC;CAC;EGR	
Date of engine manufacture	2004	
Advertised Output (SAE gr.)	170 HP / 2200 rpm	
Fuel rate at adv. output	128.4 mm <sup>3</sup> / stroke	
Valve lash cold (ins.)	0.016 int. 0.024 exh.	
Basic injection timing	11°±1° BTDC	
Idle speed	700 ± 50 rpm	

This engine conforms to U.S. EPA, California and Canada regulations, applicable to 2004 Model Year new heavy duty engines. This engine has a primary intended service application as a medium HD diesel engine. This engine is not certified for use in an urban bus as defined at 40 CFR 86.093.2. Sales of this engine for use in an urban bus is a violation of Federal Law under the Clean Air Act.

This engine is certified to be operated on diesel fuel.

44024

**Figure 2 Emission Label, 4-Cylinder EGR Engine**

See Figure 3 for the emission label for the 6-cylinder non-EGR model. .



**Figure 3 Emission Label, Non-EGR 6-Cylinder**

See Figure 4 for the 4-cylinder non-EGR model

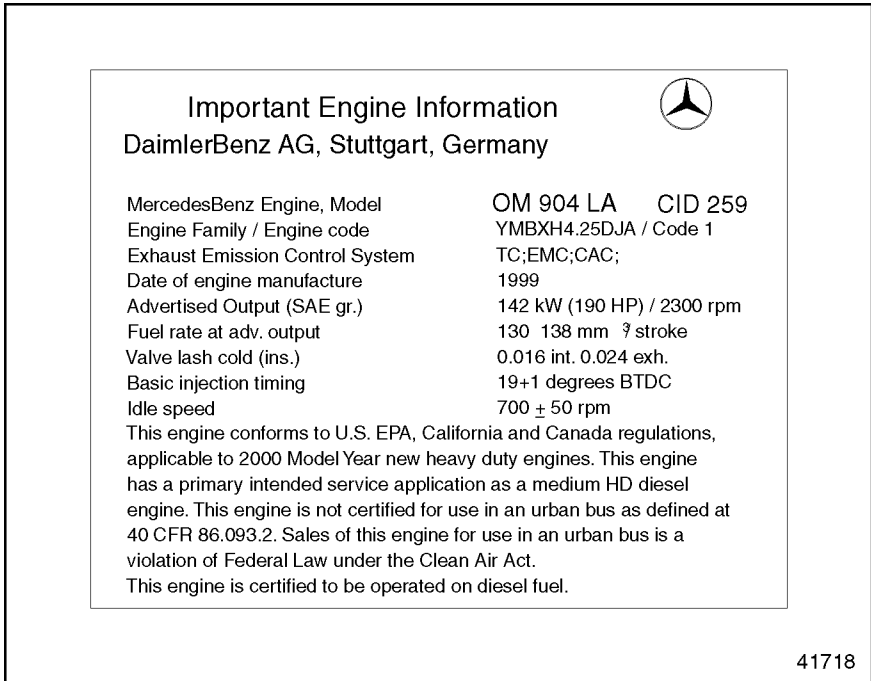

**Figure 4 Emission Label, Non-EGR 4-Cylinder**

Despite this, the engine may constitute a risk of damage to property or injury to persons under the following conditions:

- It is not used for its intended purpose.
- It is modified or converted in an incorrect manner.
- The safety instructions included in this manual are disregarded.

### Personnel Requirements

Work on the engine should be carried out only by skilled technicians who have been instructed in the specific skills necessary for the type of work being performed.

## Engine Conversions and Modifications

The function and safety of the engine could be affected if unauthorized modifications are made. Detroit Diesel will not accept responsibility for any resulting damage.

Tampering with the fuel injection system and engine electronics could also affect the engine's power output or exhaust emission levels. Compliance with the manufacturer's settings and with statutory environmental protection regulations cannot then be guaranteed.

## General View of the MBE900 Engine

The 2004 on-highway MBE900 engine is equipped with an Exhaust Gas Recirculation (EGR) system to reduce engine exhaust gas emissions in accordance with EPA regulations. See Figure 5 for a right front view of the MBE900 EGR engine, 6-cylinder model, and Figure 6 for a left rear view.

The off-highway engine used in construction and industrial applications does not have an EGR system. See Figure 7 for a front view of the MBE900 non-EGR engine, 6-cylinder model, and Figure 8 for a side view of the 6-cylinder model (right-hand side).

See Figure 9 for a front view of the MBE900 non-EGR engine, 4-cylinder model, and Figure 9 for a rear view of the 4-cylinder model.

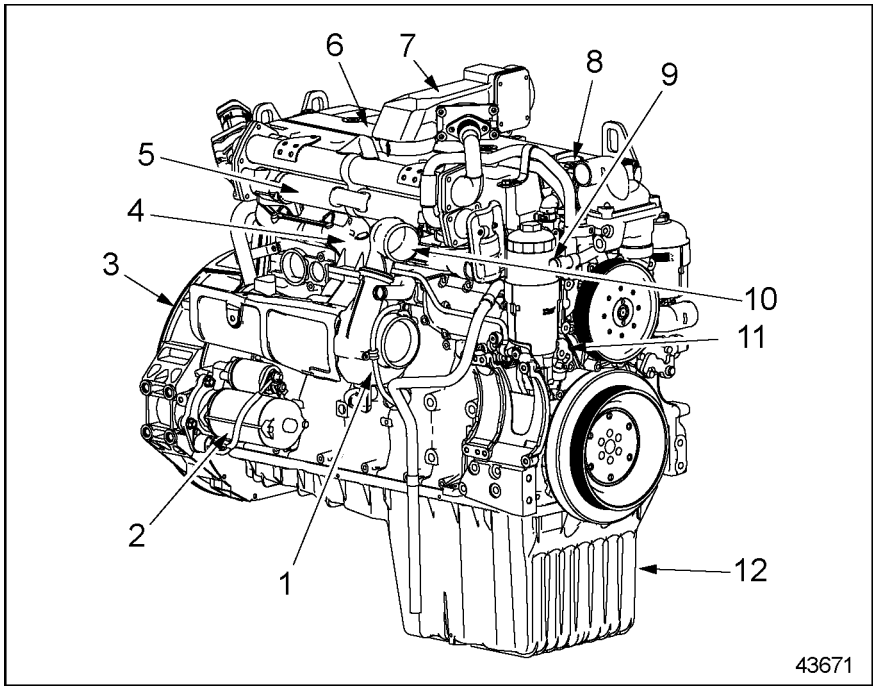

- |                        |                                 |
|------------------------|---------------------------------|
| 1. Turbocharger        | 7. EGR Mixer                    |
| 2. Starter Motor       | 8. Oil Fill Cap                 |
| 3. Flywheel Housing    | 9. Oil Filter                   |
| 4. Exhaust Manifold    | 10. Turbocharger Compressor Out |
| 5. EGR Cooler          | 11. Belt Tensioner Assembly     |
| 6. Cylinder Head Cover | 12. Oil Pan                     |

**Figure 5 Right Front View of the MBE900 EGR Engine**



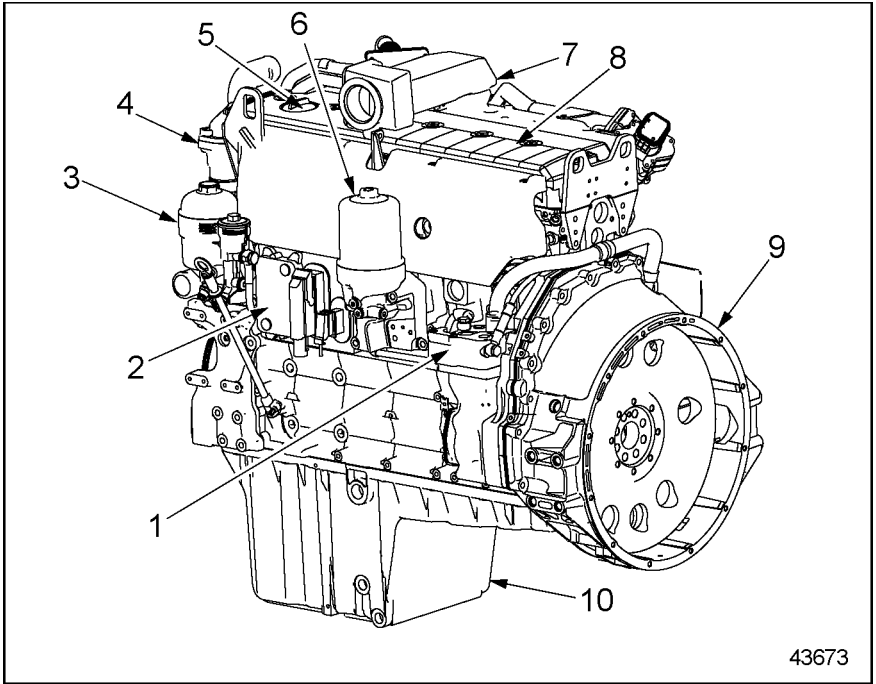

43673

- |                       |                        |
|-----------------------|------------------------|
| 1. Air Compressor     | 6. Oil Centrifuge      |
| 2. DDEC-ECU           | 7. EGR Mixer           |
| 3. Fuel Filter        | 8. Cylinder Head Cover |
| 4. Thermostat Housing | 9. Flywheel Housing    |
| 5. Oil Fill Cap       | 10. Oil Pan            |

**Figure 6 Left Rear View of the MBE900 EGR Engine**

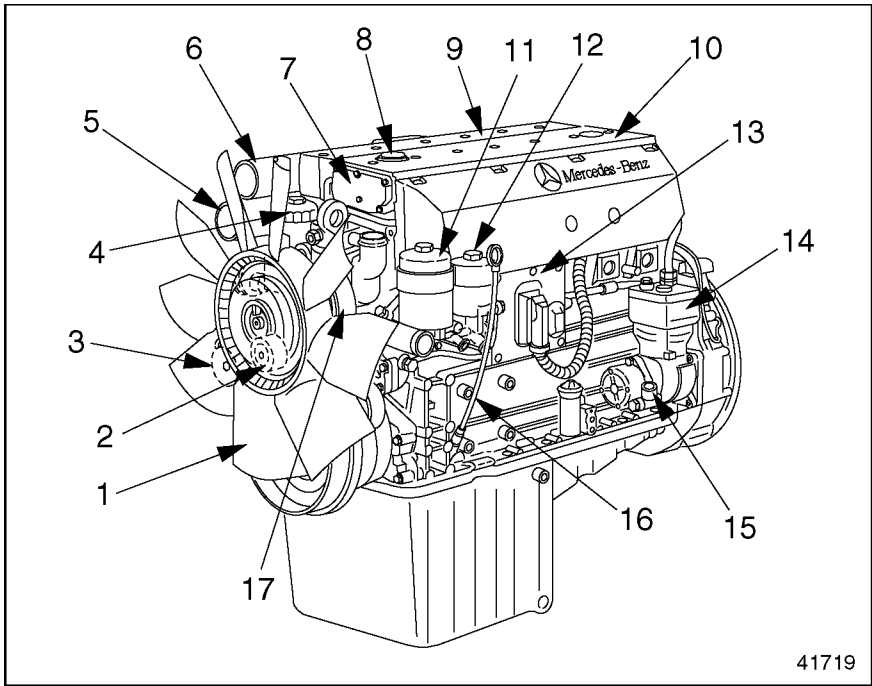

41719

- |                          |                               |
|--------------------------|-------------------------------|
| 1. Fan                   | 10. Cylinder Head Cover       |
| 2. Belt Tensioner        | 11. Fuel Filter               |
| 3. Alternator Pulley     | 12. Fuel Prefilter            |
| 4. Oil Filter            | 13. DDEC-ECU                  |
| 5. Turbo Compressor Out  | 14. Air Compressor (optional) |
| 6. Intake Manifold Inlet | 15. Power-Steering Pump       |
| 7. Crankcase Breather    | 16. Oil Dipstick              |
| 8. Oil Fill Cap          | 17. Coolant Pump Pulley       |
| 9. Intake Manifold       |                               |

**Figure 7 Front View of 6-Cylinder MBE900 Non-EGR Engine**

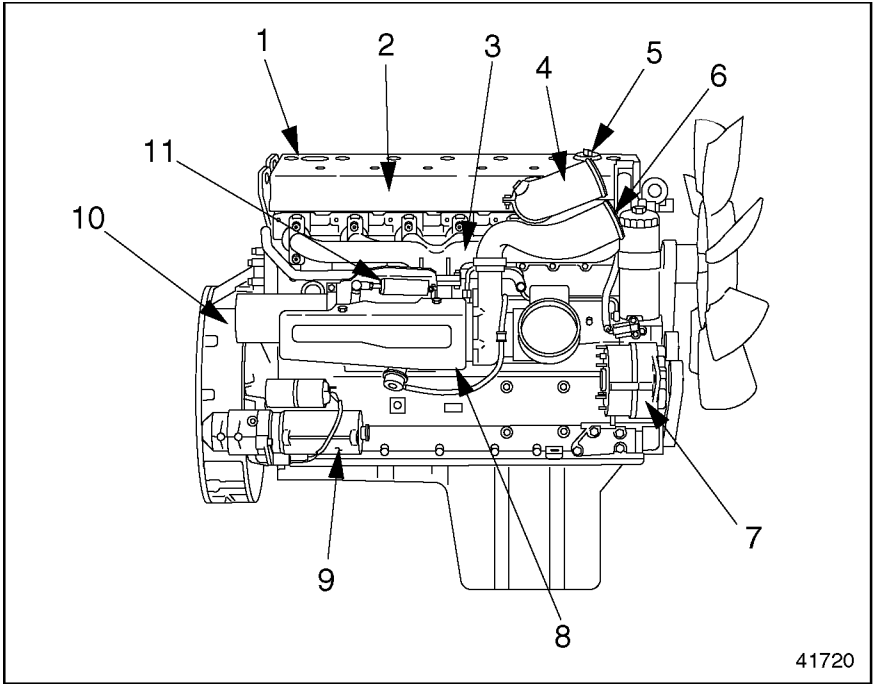

- |                          |                              |
|--------------------------|------------------------------|
| 1. Cylinder Head Cover   | 7. Alternator                |
| 2. Intake Manifold       | 8. Turbocharger              |
| 3. Exhaust Manifold      | 9. Starter Motor             |
| 4. Intake Manifold Inlet | 10. Flywheel Housing         |
| 5. Oil Fill Cap          | 11. Exhaust Brake (optional) |
| 6. Turbo Compressor Out  |                              |

**Figure 8 Side View of a 6-cylinder MBE900 Non-EGR Engine**

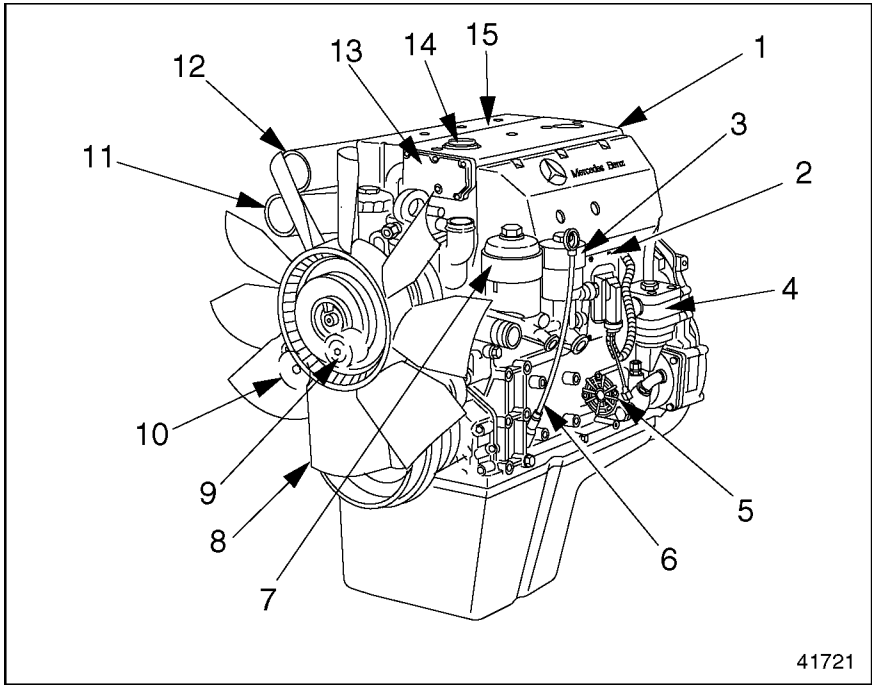

41721

- |                              |                           |
|------------------------------|---------------------------|
| 1. Cylinder Head Cover       | 9. Belt Tensioner         |
| 2. DDEC-ECU Control Unit     | 10. Alternator Pulley     |
| 3. Fuel Prefilter            | 11. Intake Manifold Inlet |
| 4. Air Compressor (optional) | 12. Turbo Compressor Out  |
| 5. Power-Steering Pump       | 13. Crankcase Breather    |
| 6. Oil Dipstick              | 14. Oil Fill Cap          |
| 7. Fuel Filter               | 15. Intake Manifold       |
| 8. Fan                       |                           |

**Figure 9 Front View of 4-Cylinder MBE900 Non-EGR Engine**

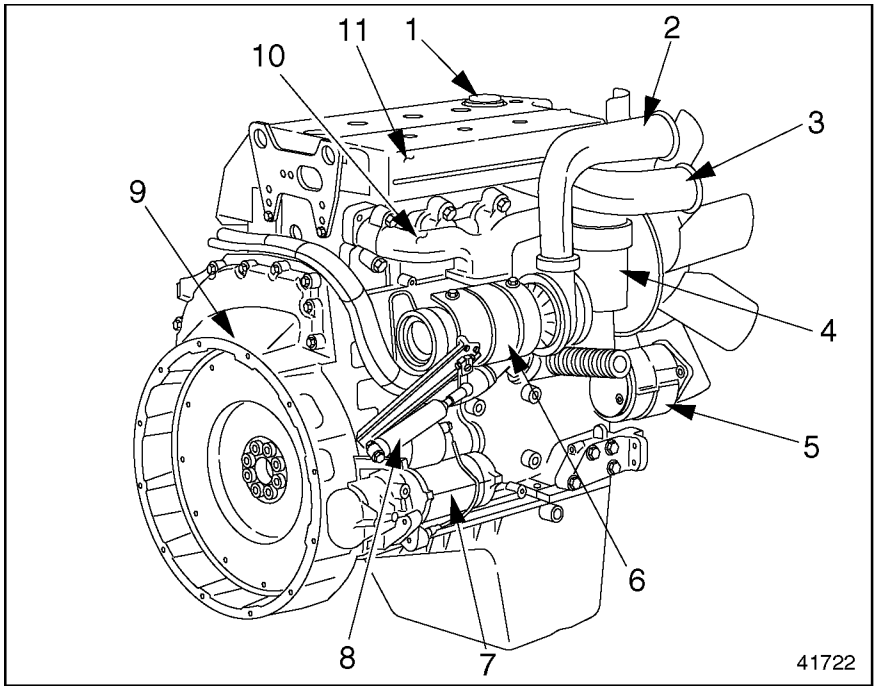

- |                            |                             |
|----------------------------|-----------------------------|
| 1. Oil Fill Cap            | 7. Starter Motor            |
| 2. Turbo Compressor Outlet | 8. Exhaust Brake (optional) |
| 3. Intake Manifold Inlet   | 9. Flywheel Housing         |
| 4. Oil Filter              | 10. Exhaust Manifold        |
| 5. Alternator              | 11. Intake Manifold         |
| 6. Turbocharger            |                             |

**Figure 10 Rear View of 4-Cylinder MBE900 Non-EGR Engine**

## Engine Identification Number

The engine identification numbers are lasered in large font onto an enlarged labeling surface on the rear right crankcase. See Figure 11.

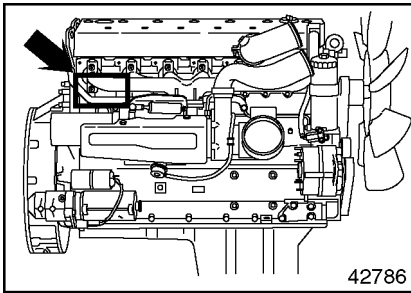

**Figure 11 Location of Engine Identification Number**

See Figure 12 for an example of the numbers as they appear on the engine.

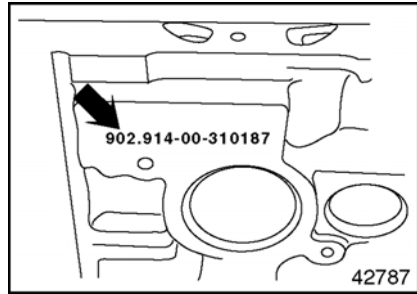

**Figure 12 Engine Identification Number**

The last six numbers are the serial numbers (310187 in Figure 12).

See Figure 13 for an explanation of the first six numbers found in the engine identification number.

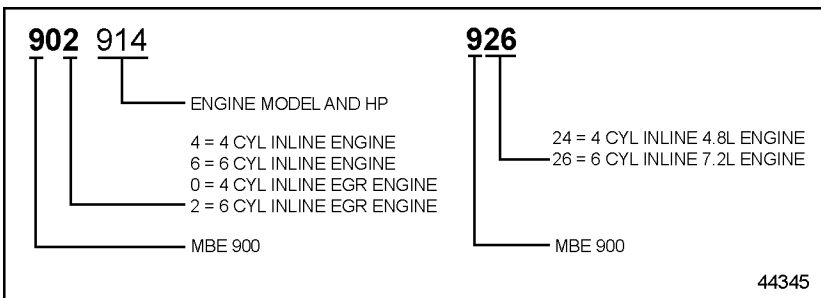

**Figure 13 Engine Identification**

**NOTE:**

In addition to the fourteen digit number etched on the crankcase, there is a ten digit number used for warranty and service that is found on the DDEC-ECU label. The ten digit number is derived from the fourteen digit number (see Figure 14).

**Description of the Engine**

All MBE900 engines are water-cooled, four-stroke, direct-injection diesel engines. The cylinders are arranged inline on both the 6-cylinder and 4-cylinder models. Each has a separate fuel injection pump (unit pump) with a short injection line to the injection nozzle, which is located in the center of the combustion chamber. The unit pumps are attached to the crankcase and are driven from the camshaft. Each cylinder has two intake valves and one exhaust valve.

Charge-air cooling and an exhaust gas turbocharger are standard equipment on all MBE900 engines (charge pressure limitation is optional).

The engine has a fully electronic control system, which regulates the fuel injection quantity and timing using solenoid valves, allowing extremely low-emission operation.

The control system consists of an engine-resident pump and nozzle control unit (the DDEC-ECU) and a vehicle control unit (the DDEC-VCU). The two are connected by a proprietary datalink.

Engine braking is controlled by a pneumatic and hydraulic (6-cylinder) operated exhaust brake on the turbocharger and by a constant-throttle system (optional).

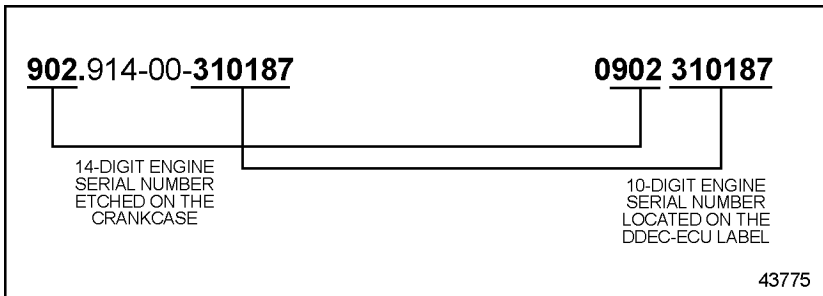

**Figure 14 Engine Serial Number**

The cylinder block has integrated oil and water channels. The upper section of the cylinder bore is induction-hardened. The single-piece cylinder head is made of cast iron. The cylinder head gasket is a metal-elastomere, adjustment-free seal with Viton® sealing elements.

The pistons are made of aluminum alloy with a shallow combustion chamber recess. The pistons are cooled by oil spray nozzles.

The crankshaft is precision-forged with seven main bearings (five on the 4-cylinder engine), six of which have custom-forged counterweights (four on the 4-cylinder engine), and a vibration damper at the front end.

The camshaft is made of case-hardened steel and has seven main bearings (five on the 4-cylinder engine). Each cylinder has cams for intake and exhaust valves and a unit pump.

The valves are controlled by mushroom tappets, pushrods, and rocker arms. The intake valves are opened and closed by a valve-guided bridge.

There is a force-feed lubricating oil circuit supplied by a rotary oil pump. This pump is positioned at the front of the crankcase and driven by gears from the crankshaft.

The oil cooler is located near the front of the crankcase on the right-hand side near the water pump.

The gear-type fuel pump is bolted to the front of the crankcase. The pump is driven from the forward end of the camshaft.

The air compressor, with a power-steering pump attached, is driven by a gear on the camshaft (optional).

The vehicle is cooled by a closed system using recirculated coolant; temperature is regulated automatically by a thermostat.

The alternator and coolant pump (and any other accessories) are driven by a belt with automatic belt tensioner.

Electrical equipment includes a starter and an alternator.

### **Exhaust Gas Recirculation**

The purpose of the Exhaust Gas Recirculation (EGR) System is to reduce engine exhaust gas emissions in accordance with EPA regulations.

The EGR system consists of an EGR cooler, EGR valve, reed valves (on the MBE904/924/926 only), and an EGR mixer.

The MBE900 engines for on-highway EPA 2004 regulation applications use a cooled EGR system.



Exhaust gases from the front three cylinders on six cylinder engines (all four cylinders on four cylinder engines) are routed from the exhaust manifold through the EGR cooler, past control and reed valves, and mixed with the intake manifold charge air. The addition of cooled exhaust gases back into the combustion airflow reduces the peak in cylinder combustion temperature. Less oxides of nitrogen (NOx) are produced at lower combustion temperatures.

## Exhaust Brake/Constant-Throttle Valves, Optional

To increase braking performance, the engine can be equipped with an exhaust brake on the turbocharger in conjunction with constant-throttle valves in the cylinder head. See Figure 15.

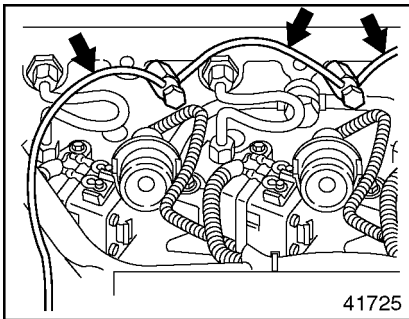

**Figure 15 Constant — Throttle Activation**

The two systems operate independently of each other and in combination.

Exhaust back pressure is used by the exhaust brake to increase braking performance. The constant-throttle valves use the air that escapes through them on the compression stroke to provide braking force.

The constant-throttles valves are small valves which are built into the cylinder head and positioned opposite the exhaust valve. When open, a link is created between the combustion chamber and the exhaust port.

When the engine brake is switched on, the constant-throttle valves are put under pressure, which in turn opens the valves.

On the 6-cylinder model, the constant-throttle valves are activated by engine oil pressure. On 4-cylinder engines, the constant-throttle valves are activated by compressor air pressure.

The engine brake is activated by the DDEC-VCU and can be activated only at engine speeds up to 2700 rpm.

Below 900 rpm, the engine brake is always turned off to prevent the engine from stalling. Also, the engine brake is automatically turned off when the accelerator pedal is pressed.

**NOTE:**

When in emergency running mode (constant rpm), the engine brake can be activated only when the engine is in overrun. When constant rpm has been attained, the engine brake is automatically turned off.

### Electronic Engine Control System

The engine is equipped with a fully electronic control system. Besides the engine and its related sensors, this system is composed of the following:

- The DDEC-ECU (engine control unit)
- The DDEC-VCU (vehicle control unit) located under the right-hand dash panel

The two control units are connected by a proprietary datalink through which all necessary data and information can be exchanged. See Figure 16.

The DDEC-VCU then broadcasts all information on the J1587 and J1939 datalinks, where it can be read by the Nexiq™ Diagnostic Data Reader (DDR), Detroit Diesel Diagnostic

Link® (DDDL) PC-based software or minidiag2.

The engine control system monitors both the engine and the datalink. When a malfunction or other problem is detected, the system selects an appropriate response; for example, the emergency running mode may be activated.

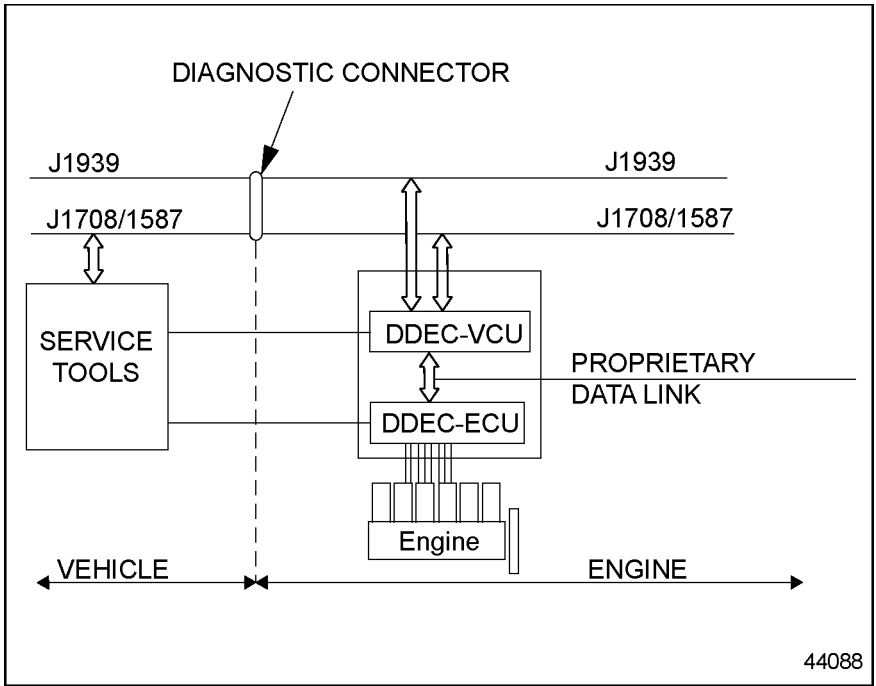
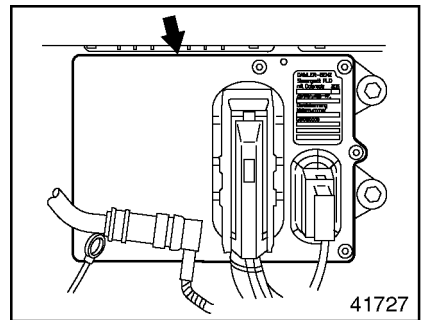

**Figure 16 Electronic Engine Control System**

**DDEC-ECU**

The DDEC-ECU (see Figure 17) is located on the left-hand side of the engine.

The DDEC-ECU processes the data received from the DDEC-VCU, for example the position of the accelerator pedal, engine brake, etc.



**Figure 17 DDEC-ECU**

These data are evaluated together with the data from the sensors on the engine, such as coolant and fuel temperature and oil and charge pressure.

The data is then compared to the characteristic maps or lines stored in the DDEC-ECU. From these data, quantity and timing of injection are calculated and the unit pumps are actuated accordingly through the solenoid valves.

### NOTE:

To obtain a replacement DDEC-ECU, all the data given on the DDEC-ECU label are required.

The DDEC-ECU data label has the 10 digit engine serial number (see Figure 14), the engine horse power and torque.

### DDEC-VCU

The DDEC-VCU communicates with any other electronic control unit installed on the vehicle over the J1587 data link. See Figure 18.

Data for specific applications is stored in the DDEC-VCU. These include idle speed, maximum running speed, and speed limitation.

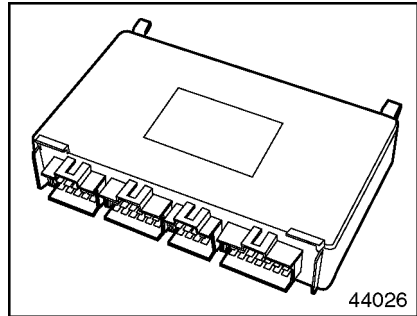

**Figure 18 DDEC-VCU**

The DDEC-VCU receives data from the following sources:

- The operator (accelerator pedal position, engine brake switch)
- Other electronic control units (for example, the anti-lock brake system)
- The DDEC—ECU (oil pressure and coolant temperature)

From these data, instructions are computed for controlling the engine and transmitted to the DDEC-ECU via the proprietary datalink.

The DDEC-VCU controls various systems, for example, communications with the datalink, the engine brake, and the constant-throttle valves.

## Sensor Locations

See Figure 19 and Figure 20 for sensor locations on the MBE900 EGR engine. See Figure 21 for sensor locations on the MBE900 non-EGR engine.



**CAUTION:**

**CHEMICAL BURNS**

To avoid injury from chemical burns, wear a face shield and neoprene or PVC gloves when handling sensor hoses.

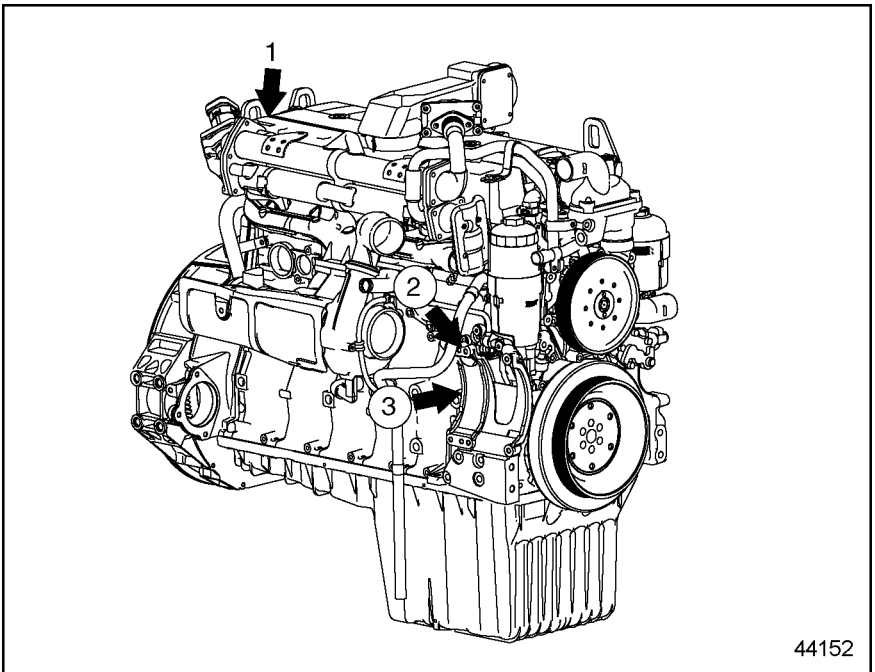

44152

1. Intake Manifold Pressure/Temperature Sensor

3. Engine Oil Pressure Sensor

2. Engine Oil Temperature Sensor

**Figure 19 Sensor Location on the Right Side of the MBE900 EGR Engine**

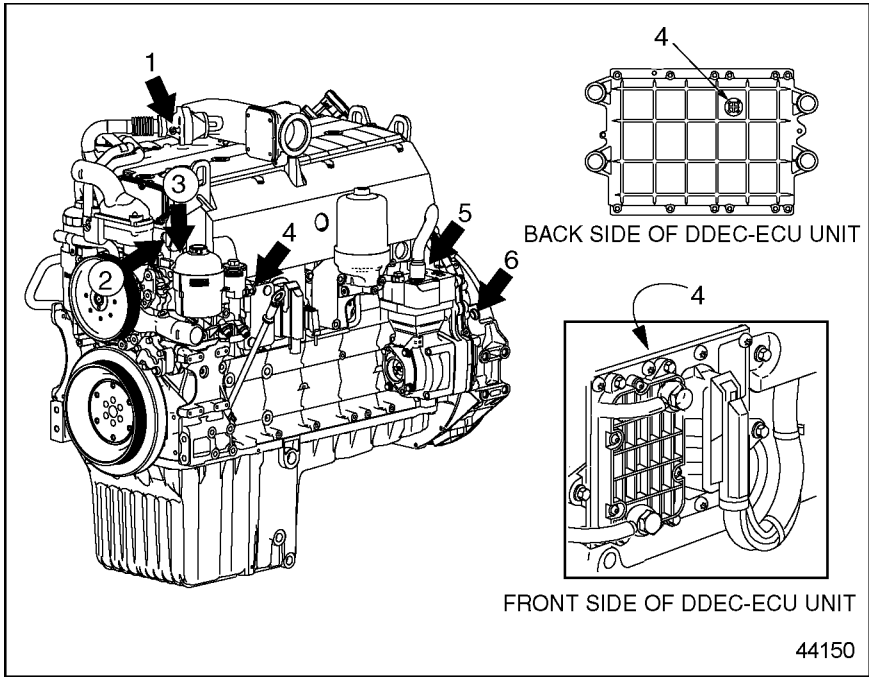

44150

- |                                      |  |
|--------------------------------------|--|
| 1. EGR Temperature Sensor            | 4. Barometric Pressure Sensor (integrated into DDEC-ECU) |
| 2. Engine Coolant Temperature Sensor | 5. Camshaft Position Sensor (on camshaft)                |
| 3. Supply Fuel Temperature Sensor    | 6. Crankshaft Position Sensor (on timing case)           |

**Figure 20 Sensor Location on the Left Side of the MBE900 EGR Engine**

**NOTE:**  
The 6-cylinder engine is shown; sensor locations are similar on the 4-cylinder engine.

**NOTE:**  
The Barometric Pressure Sensor is integrated into the DDEC-ECU.

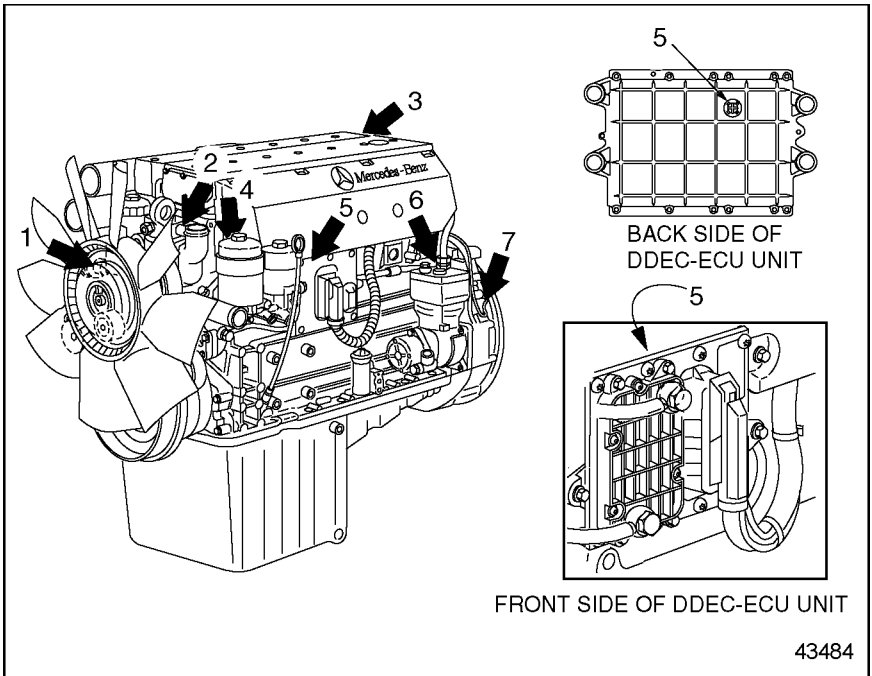

- |  |  |
|--|--|
| 1. Engine Oil Pressure/Temperature Sensor      | 5. Barometric Pressure Sensor (integrated into DDEC-ECU) |
| 2. Engine Coolant Temperature Sensor           | 6. Camshaft Position Sensor (on camshaft)                |
| 3. Intake Manifold Pressure/Temperature Sensor | 7. Crankshaft Position Sensor (on timing case)           |
| 4. Supply Fuel Temperature Sensor              |  |

**Figure 21 Sensor Location on the MBE900 Non-EGR Engine**

**NOTE:**

The 6-cylinder engine is shown; sensor locations are similar on the 4-cylinder engine.

**NOTE:**

The Engine Oil Level Sensor, if used, is located at the bottom of the oil pan.

## OPERATION

**Important:** Before starting the engine, do all the recommended pretrip inspections and daily maintenance. Check the engine oil and fuel levels, and drain contaminants from the fuel/water separator (optional).

### Before Starting the Engine

**NOTE:**

If you drain the fuel/water separator completely, you may have to prime the fuel system.

Be sure you are familiar with all of the instruments, gauges and controls which are needed to operate the engine.

Note especially the location and function of the following:

- Oil Pressure Gauge
- Coolant Temperature Gauge
- Low Oil Pressure/High Coolant Temperature Warning Light
- Water In Fuel Warning Light
- Tachometer
- Air Restriction Indicator

When starting the engine, and while driving, watch for any signs of engine problems. If the engine overheats, uses excessive fuel or lubricating oil, vibrates, misfires, makes unusual

noises, or shows an unusual loss of power, turn the engine off as soon as possible and determine the cause. Frequently, engine damage may be avoided by a quick response to early indications of problems.

If you are starting the engine in cold weather, refer to "Cold Weather Products" in the "Service Products" section of this manual.

### Checking the Batteries

Use only batteries that have been correctly filled and serviced. To provide corrosion protection, apply dielectric grease, part number 48-02349-000, liberally to the terminal pads. Approved suppliers are listed in Table 1.

Manufacturer	Lubricant or Part Number
Shell Oil, Co.	No. 71032; No. 71306
Texaco, Inc.	No. 955
Quaker State	No. NYK-77

**Table 1 Approved Electrical Lubricants**



**! WARNING:**  
**Battery Explosion and Acid Burn**

To avoid injury from battery explosion or contact with battery acid, work in a well ventilated area, wear protective clothing, and avoid sparks or flames near the battery. If you come in contact with battery acid:

- ❑ Flush your skin with water.
- ❑ Apply baking soda or lime to help neutralize the acid.
- ❑ Flush your eyes with water.
- ❑ Get medical attention immediately.

**Checking the Oil Level**

Check the oil level as follows:

1. Check the oil level using the oil dipstick (see Figure 22).

**! WARNING:**  
**PERSONAL INJURY**

To avoid injury from slipping and falling, immediately clean up any spilled liquids.

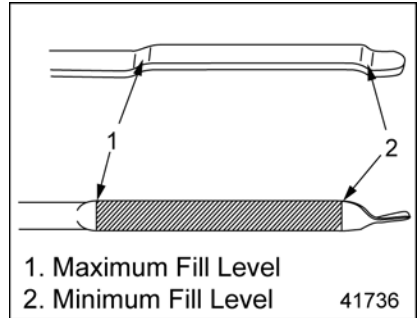

**Figure 22 Oil Dipstick**

2. If necessary, top off by filling engine oil through the oil fill collar (see Figure 23) until the maximum fill level on the oil dipstick (see Figure 22) has been reached. For detailed procedures, refer to the "Maintenance" section. Do not overfill.

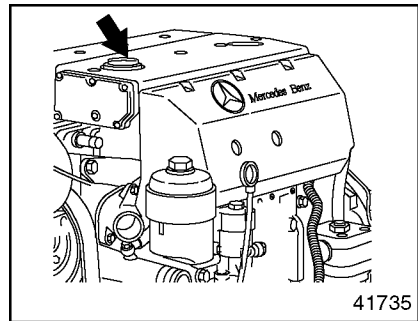

**Figure 23 Oil Fill Collar**

## Checking the Coolant Level (Cold Check)

Check the coolant level as follows:

1. Ensure that all coolant plugs in the bottom of the radiator and on the radiator outlet pipe are secure and tight.
2. Check the coolant level. The cooling system is correctly filled when the coolant is between the maximum and minimum marks on the surge tank.

### NOTE:

For more information, refer to the "Maintenance" section.

## Adding Fuel

Note the following when adding fuel:

- Add winter or summer grade fuel according to the season of the year.
- Work in the cleanest conditions possible.
- Prevent water from entering the fuel tank. For further information refer to "Diesel Fuels" in "Service Products."

## Priming the Fuel System

Prime the fuel system as follows:

### NOTICE:

Correct torque on the high pressure lines is critical. Incorrect torques could result in leaks or lack of power due to restricted fuel flow.

1. Make sure that all high-pressure and low-pressure lines are securely tightened.
2. If equipped with a hand pump on the fuel/water separator, work the hand pump 50 times.
3. Crank the engine for 30 seconds at a time, but *no longer*. Before cranking the engine again, wait at least two minutes. The engine should start within six 30-second attempts.

## Starting the Engine

Before operating the engine, follow the steps described in the "Before Starting the Engine" section. Start the engine as follows:

### NOTE:

As a safety function, the electronic engine control system may be wired to start the engine only if the transmission is in neutral. This is vehicle application specific.

**NOTICE:**

Never attempt to start the Mercedes-Benz MBE900 engine using ether or any other starting fluid. Serious engine damage could result.

1. Turn on the ignition switch.
2. With the accelerator pedal in the idle position, start the engine.



**WARNING:  
PERSONAL INJURY**

To avoid injury when working near or on an operating engine, remove loose items of clothing and jewelry. Tie back or contain long hair that could be caught in any moving part causing injury.

3. Check the engine for leaks.
  - [a] Check all hoses, hose clamps, and pipe unions on the engine for tightness. Shut down the engine and tighten them if necessary.
  - [b] Check the oil feed and return lines at the turbocharger for tightness. Shut down the engine and tighten them if necessary.
4. Shut down the engine.

5. Approximately five minutes after shutdown, check the engine oil level. If necessary, add oil up to the maximum fill level on the oil dipstick (see Figure 24). Do not overfill.

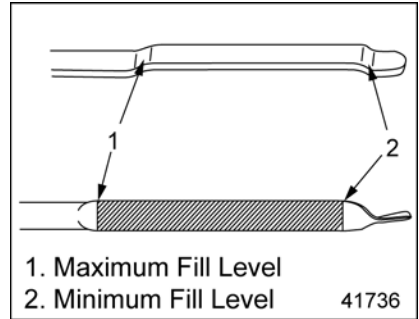

**Figure 24 Oil Dipstick**

6. Check all the mounting fasteners and belts on the engine for tightness.

**Checking the Coolant Level (Hot Check)**

Check coolant level as follows:

1. Allow the engine to run for approximately five minutes at a moderate speed.



**WARNING:**

**HOT COOLANT**

To avoid scalding from the expulsion of hot coolant, never remove the cooling system pressure cap while the engine is at operating temperature. Wear adequate protective clothing (face shield, rubber gloves, apron, and boots). Remove the cap slowly to relieve pressure.

2. Then, with the coolant temperature above 50°C (122°F), recheck the coolant level.
3. Add more coolant if necessary. Open the heater valves before adding coolant.
4. Do not close the heater valves until the engine has been run briefly and the coolant level again checked and corrected as necessary.

**Starting an Engine That Has Not Been Run for an Extended Period**

Before starting an engine which has not been run for an extended period, certain special work must be carried out. Refer to “Storage,” under “Cleaning and Storage.”

**Important:** At outside temperatures below -20°C (-4°F), a coolant preheater is recommended.

1. Chock the tires, place the transmission in neutral, and set the parking brake.
2. Turn on the ignition switch and start the engine
3. If the engine doesn't start after 20 seconds, stop. Try again after waiting about one minute.

**NOTICE:**

Do not rev the engine if the oil pressure gauge indicates no oil pressure. To avoid engine damage, shut down the engine if no oil pressure appears within approximately ten seconds. Check to determine the cause of the problem.

4. Monitor the oil pressure gauge immediately after starting the engine.

**NOTE:**

Do not place the engine under full load until it reaches operating temperature.

## Monitoring Engine Operation

While the engine is operating, monitor the battery charge indicator light, the oil pressure and avoid excessive idling.

### Battery Charge

The battery charge indicator light (see Figure 25) must go out once the engine starts.

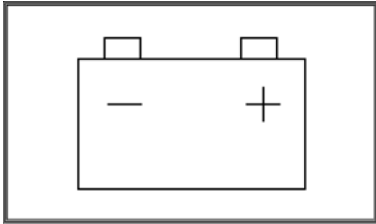

41737

**Figure 25 Battery Charge Indicator Light**

If the indicator light comes on while the engine is running, do the following:



## WARNING:

### FIRE

**To avoid injury from fire, keep all potential ignition sources away from diesel fuel, including open flames, sparks, and electrical resistance heating elements. Do not smoke when refueling.**

1. Shut down the engine.
2. Check the poly-V belt for tightness.
3. Do a load test on the batteries. Charge or replace the batteries as needed.
4. If necessary, visit the nearest authorized dealer to have the alternator voltage and output checked.

### Oil Pressure

When the engine has reached its normal operating temperature, the engine oil pressure must not drop below the following values:

- 36 psi (250 kPa) at rated speed
- 7 psi (50 kPa) at idling speed

If oil pressure drops below these values, stop the engine and determine the cause.

### Excessive Idling

Never allow the engine to idle for more than 30 minutes. Excessive idling can cause oil to leak from the turbocharger.

### Changing the Idle Speed

The rpm range of the MBE900 engine is 600 rpm to 850 rpm if the parameters in the DDEC-VCU are set to the default range.

Change the idling speed as follows:

1. Turn the cruise control switch to the OFF position.
2. To increase the idle speed, push the "Resume" switch until the idle is fast enough.
3. To decrease the idle speed, push the "Decel" switch until the idle is slow enough.

### Shutting Down the Engine

If the engine has been running at full output or the coolant temperature has been high, allow the engine to idle for one to two minutes without load. Then turn off the ignition key switch.

If any the following occur, shut down the engine immediately.

- The oil pressure swings back and forth or falls sharply.

- Engine power and rpm fall, even though the accelerator pedal remains steady.
- The exhaust pipe gives off heavy smoke.
- The coolant and/or oil temperature climb abnormally.
- Abnormal sounds suddenly occur in the engine or turbocharger.

### Shutting Down After Hard Operation

NOTICE:
After hard operation, if the engine has been running at full output or the coolant temperature has been high, allow the engine to idle for one to two minutes without load. Shutting down the engine without idling may cause damage to the turbocharger.

Turn off the ignition switch and shut down the engine.

## Emergency Running Mode

The engine is equipped with the electronic engine control system, which monitors the engine as it is running.

As soon as a fault is detected, it is evaluated and one of the following measures is initiated.

### NOTICE:

To prevent possible serious engine damage, have any faults corrected without delay by an authorized dealer.

- In conjunction with the instrumentation control unit (ICU), the code for the electronic control unit reporting the fault can be read immediately on the display.
- Complete fault codes are transmitted and can be read using ServiceLink at any authorized dealer.
- If the fault is serious enough to impair normal operation, the electronic engine system switches over to emergency running mode. When in emergency running mode, the engine operates at a constant 1300 rpm. This allows you to move the vehicle to a service location.

## Stop Engine Override Option

The Stop Engine Override Option is used for a momentary override. The DDEC-ECU will record the number of times the override is activated after a fault occurs.

**Momentary Override** – A Stop Engine Override (SEO) switch is used to override the shutdown sequence (see Figure 26). This override resets the 60 second (30 seconds for oil pressure) shutdown timer, restoring power to the level when the Red Stop Lamp (RSL) was illuminated. The switch must be recycled after five seconds to obtain a subsequent override.

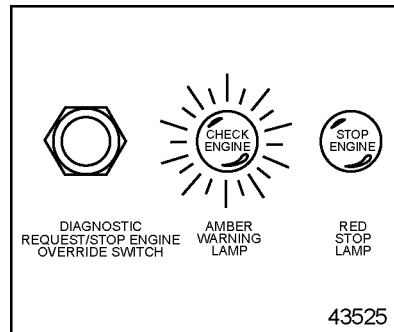

**Figure 26 Typical SEO Switch and Warning Lamps**

### NOTE:

The operator has the responsibility to take action to avoid engine damage.

## **Cold Weather Operation**

Special precautions must be taken during cold weather. To protect your engine, special cold weather handling is required for fuel, engine oil, coolant, and batteries. For detailed information, refer to the service manual.

## **Winter Fronts**

A winter front may be used to improve cab heating while idling. At least 25% of the grill opening should remain open in sectioned stripes that run perpendicular to the charge air cooler tube flow direction. This assures even cooling across each tube and reduces header to tube stress and possible failure. Winter fronts should only be used when the ambient temperature remains below  $-12.2^{\circ}\text{C}$  ( $10^{\circ}\text{F}$ ).



## CLEANING AND STORAGE

When an engine is to be stored for a period of time, special precautions should be taken to protect the interior and exterior of the engine.

### Cleaning the Engine

**Important:** Observe all environmental protection regulations.

#### High-Pressure Cleaning Equipment

Note the equipment manufacturer's operating instructions.

<b>NOTICE:</b>
To prevent damage to engine components during the cleaning process, keep the water moving at all times. Never direct water onto electrical components, plug connectors, seals or flexible hoses.

After cleaning, and especially when using a high-pressure jet or grease-removing agent, lubricate the engine. Information on suitable cleaning and protective products is available from any authorized dealer.

### Cleaning the Cooling System

**Important:** Collect the used coolant, cleaning solutions, and washing liquids. Dispose of them in accordance with applicable laws regarding the protection of the environment.

<b>NOTICE:</b>
Clean at moderate pressures only; otherwise the fins of the radiator grille could be damaged.

Comply with the minimum working distance between the high-pressure nozzle and the surface being cleaned:

- Approximately 700 mm (28 in.) for circular pattern jets
- Approximately 300 mm (12 in.) for 25-degree flat jets and dirt cutters

Clean as follows:

 <b>WARNING:</b> <b>EYE INJURY</b>
<b>To avoid injury from flying debris when using compressed air, wear adequate eye protection (face shield or safety goggles) and do not exceed 276 kPa (40 psi) air pressure.</b>

1. Remove debris (dust, insects, etc.) from the fins of the radiator grille by blowing them through with compressed air or spraying them out with water. Work from the rear of the radiator (in the opposite direction of the normal cooling air flow).
2. Drain the coolant when the engine is cold. For detailed procedures, see the vehicle/chassis maintenance manual. For types of coolant, refer to “Coolant” in the “Service Products” section.
3. If the HVAC unit is connected to the cooling system, open the regulating valves all the way.

### Degreasing

Degrease as follows:

1. Fill the cooling system with a 5% solution (1.6 ounces per quart of

water—50 grams per liter) of a mildly alkaline cleaning agent, such as sodium carbonate.

2. Run the engine at moderate speed until the thermostat starts to open, at an operating temperature of approximately 80°C (176°F). Then run it for about five minutes longer. Shut down the engine and allow it to cool to approximately 50°C (112°F).

 <b>WARNING:</b> <b>HOT COOLANT</b>
<b>To avoid scalding from the expulsion of hot coolant, never remove the cooling system pressure cap while the engine is at operating temperature. Wear adequate protective clothing (face shield, rubber gloves, apron, and boots). Remove the cap slowly to relieve pressure.</b>

3. Drain all the cleaning solution.
4. Flush the cleaning solution from the cooling system.
  - [a] Immediately after draining the cleaning solution, flush the system with clean water.
  - [b] Once the clean water has drained, fill the system again with clean water.

[c] Run the engine. Allow the engine to warm up to approximately 80°C (176°F), and then run it about five minutes longer.

[d] Drain the hot water.

5. Fill the cooling system with new coolant. For detailed procedures, see the vehicle/chassis maintenance manual. For types of coolant, refer to “Coolant” in the “Service Products” section.

If the engine is to be out of service for over 12 months, or under extraordinary storage or transportation conditions, then special protective measures are necessary. Information is available from any authorized dealer. It is strongly recommended that you request this information.

**Important:** If the engine is to be out of service for over 18 months, the oil must be changed before the engine can be brought back into service.

## Storage

Required protective measures for the MBE900 engine depend on the following:

- The length of time that the engine will be out of service
- The climate and conditions where the engine is stored

After cleaning, engines should, whenever possible, be placed in a dry, well-ventilated area.

In all cases, protect the engine against direct exposure to moisture (rain/splash water).

If the engine is to be out of service for 12 months or less, anticorrosion measures are not necessary, provided that the place of storage are dry and well-ventilated as described above.

## TROUBLESHOOTING

In addition to operating the engine carefully and maintaining it properly, make sure to correct any malfunction promptly.

### Emergency Starting

For emergency starting procedures (jump starting), see the driver's/operator's manual under the heading "Emergency Starting With Jumper Cables."

### Troubleshooting the Electronic Engine Control System

When the electronic engine control system detects a fault, it broadcasts a message on the datalink. The dash display will show the code "ECU 128," indicating there is an engine fault.

**Important:** To read the complete fault code, bring the vehicle to an authorized dealer. Complete fault codes can be read using ServiceLink.

For fault codes and their meanings, see the service/workshop manual.

### General Troubleshooting

The tables that follow are designed to identify the causes of common problems, suggest further checks and appropriate remedies. When dealer service is necessary, it is mentioned in the table.

**NOTE:**

Remember to follow all cautions when troubleshooting the engine.

<b>Problem - The Engine Will Not Crank</b>	
<b>Cause</b>	<b>Remedy</b>
The batteries are damaged or weak.	Test the batteries. Replace them, if needed.
The ignition switch is damaged.	Replace the ignition switch.
The battery cables are damaged and/or corroded.	Replace the battery cables.
The starter is damaged and/or worn.	Have an authorized dealer replace the starter.
The clutch or transmission is damaged.	Bring the vehicle to an authorized dealer for service.
There is internal damage to the engine.	Bring the vehicle to an authorized dealer for service.

<b>Problem—The Engine Turns Over Slowly</b>	
<b>Cause</b>	<b>Remedy</b>
The batteries are damaged or weak.	Test the batteries. Replace them, if needed.
The ignition switch is damaged.	Replace the ignition switch.
The battery cables are damaged and/or corroded	Replace the battery cables.
The starter is damaged and/or worn.	Have an authorized dealer replace the starter.
The engine oil does not meet the correct specifications.	Change the engine oil, using the correct type of oil.
The transmission fluid does not meet the correct specifications.	Change the transmission fluid, using the correct type of fluid.

<b>Problem—The Engine Cranks, But Won't Start</b>	
<b>Cause</b>	<b>Remedy</b>
The batteries are damaged or weak.	Test the batteries. Replace them, if needed.
The cranking speed is not set correctly.	Bring the vehicle to an authorized dealer for service.
No intake air preheater is installed, and it is too cold to start without one.	Install an intake air preheater.
The intake air preheater is malfunctioning.	Check the intake air preheater, and replace it, if necessary.
The camshaft TDC sensor and/or the crank angle position sensor are out of adjustment.	Push both sensors into their holes as far as they will go. If this does not solve the problem, bring the vehicle to an authorized dealer for service.
The camshaft TDC sensor and/or the crank angle position sensor are damaged.	Bring the vehicle to an authorized dealer for service.
There is air in the fuel system.	Check the fuel lines for leaks. Bleed the fuel system and start the engine according to the instructions in the service manual.
The air filter is clogged.	Clean or replace the air filter.
The fuel filter is clogged.	Replace the filter element.
The exhaust brake valve is malfunctioning.	Have an authorized dealer check the operation of the valve.
The valves are not adjusted properly.	Check the valve lash.
There are other problems in the fuel system.	Bring the vehicle to an authorized dealer for service.
Coolant level is too low.	Check for leaks, add coolant to correct level.

<b>Problem—The Engine Starts Only After Cranking for a Long Time</b>	
<b>Cause</b>	<b>Remedy</b>
The fuel tank is low or empty.	Add fuel and bleed the fuel system, if necessary.
There are leaks in the fuel lines.	Check the fuel lines for leaks and repair them, if necessary.
The fuel filter is clogged.	Replace the filter element.
The fuel line, the fuel prefilter, or the screen in the fuel tank is blocked.	Clean and bleed the system. Have the fuel lines and filters checked by an authorized dealer.
The camshaft TDC sensor and/or the crank angle position sensor are out of adjustment.	Push both sensors into their holes as far as they will go. If this does not solve the problem, bring the vehicle to an authorized dealer for service.
The camshaft TDC sensor and/or the crank angle position sensor are damaged.	Bring the vehicle to an authorized dealer for service.
There are other problems in the fuel system.	Bring the vehicle to an authorized dealer for service.

<b>Problem—The Engine Starts, But Dies</b>	
<b>Cause</b>	<b>Remedy</b>
The fuel tank is low or empty.	Add fuel and bleed the fuel system, if necessary.
The fuel filter is clogged.	Replace the filter element.
The fuel line, the fuel prefilter, or the screen in the fuel tank is blocked.	Clean and bleed the system. Have the fuel lines and filters checked by an authorized dealer.
The camshaft TDC sensor and/or the crank angle position sensor are out of adjustment.	Push both sensors into their holes as far as they will go. If this does not solve the problem, bring the vehicle to an authorized dealer for service.
The camshaft TDC sensor and/or the crank angle position sensor are damaged.	Bring the vehicle to an authorized dealer for service.
The constant-throttle valves are malfunctioning.	Bring the vehicle to an authorized dealer for service.
There are other problems in the fuel system.	Bring the vehicle to an authorized dealer for service.

<b>Problem—The Engine Fan Doesn't Work</b>	
<b>Cause</b>	<b>Remedy</b>
The fan hub is damaged.	Replace the fan hub.
The fan wiring is damaged.	Repair the fan wiring.
The parameter settings in the DDEC-ECU or DDEC-VCU are incorrect.	Have an authorized dealer reprogram the control unit.



<b>Problem—The Engine Fan Is Constantly On</b>	
<b>Cause</b>	<b>Remedy</b>
The fan override switch is on.	Check the operation of the fan override switch.
The fan hub is damaged.	Replace the fan hub
The parameter settings in the DDEC-ECU or DDEC-VCU are incorrect.	Have an authorized dealer reprogram the control unit.

<b>Problem—Fuel Consumption Is Too High</b>	
<b>Cause</b>	<b>Remedy</b>
The tires are not properly inflated.	Check all tires for correct pressure.
The air filter and/or intake air system is clogged.	Check the air restriction indicator. Clean the intake air system and replace the air filter if necessary.
The fuel filter is clogged.	Replace the filter element.
The exhaust brake valve is malfunctioning.	Have an authorized dealer check the operation of the valve.
The engine performs poorly, or does not develop full power.	The remedies are listed in -47" The Engine Performs Poorly, Does Not Develop Full Power" in this section.

<b>Problem—The Engine Performs Poorly, Does Not Develop Full Power</b>	
<b>Cause</b>	<b>Remedy</b>
The air filter and/or intake air system is clogged.	Check the air restriction indicator. Clean the intake air system and replace the air filter if necessary.
The exhaust brake valve is malfunctioning.	Have an authorized dealer check the operation of the valve.
The fuel filter is clogged.	Replace the filter element.
There are other problems with the fuel system.	Bring the vehicle to an authorized dealer for service.
The valves are not adjusted properly	Check the valve lash.
The coolant temperature sensor is damaged or reading incorrectly.	Bring the vehicle to an authorized dealer for service.
The fuel temperature sensor is damaged or reading incorrectly.	Bring the vehicle to an authorized dealer for service.
The engine oil temperature sensor is damaged or reading incorrectly.	Bring the vehicle to an authorized dealer for service.
The charge-air temperature sensor is damaged or reading incorrectly.	Bring the vehicle to an authorized dealer for service.
There are problems with the DDEC-ECU or DDEC-VCU.	Bring the vehicle to an authorized dealer for service.
There is internal damage to the engine.	Bring the vehicle to an authorized dealer for service.

<b>Problem—The Engine Is in Emergency Running Mode (constant speed 1,300 rpm)</b>	
<b>Cause</b>	<b>Remedy</b>
The DDEC-ECU or DDEC-VCU or sensor(s), solenoids and other electronic parts are damaged.	Bring the vehicle to an authorized dealer for service.

<b>Problem—The Coolant Temperature Is Above Normal</b>	
<b>Cause</b>	<b>Remedy</b>
The coolant level is too low.	Check for coolant leaks, and repair as needed.
The poly-V belt is loose.	Tighten or replace the poly-V belt.
The coolant temperature gauge and/or sensor is not reading correctly.	Bring the vehicle to an authorized dealer for service.
The radiator is damaged or dirty.	Clean the radiator. Repair or replace the radiator if necessary.
The coolant pump is damaged.	Have an authorized dealer replace the coolant pump.
The thermostat is damaged.	Have an authorized dealer replace the coolant pump.
The fan is not operating properly.	Bring the vehicle to an authorized dealer and have the fan hub checked. Bring the vehicle to an authorized dealer and have the parameter settings reprogrammed in the DDEC-ECU or DDEC-VCU.

<b>Problem—The Coolant Temperature Is Below Normal</b>	
<b>Cause</b>	<b>Remedy</b>
The coolant temperature gauge and/or sensor is not reading correctly.	Bring the vehicle to an authorized dealer for service.
The thermostat is damaged.	Have an authorized dealer replace the thermostat.
The fan is not operating properly.	Bring the vehicle to an authorized dealer and have the fan hub checked. Bring the vehicle to an authorized dealer and have the parameter settings reprogrammed in the DDEC-ECU or DDEC-VCU.

<b>Problem—The Cooling System Is Losing Coolant</b>	
<b>Cause</b>	<b>Remedy</b>
There is an external coolant leak.	Repair the leaking component.
The radiator cap is leaking.	Replace the radiator cap.
The air compressor head is damaged.	Have an authorized dealer replace the air compressor.
The cylinder head gasket is leaking.	Have an authorized dealer replace the head gasket.
Top tank is leaking.	Bring the vehicle to an authorized dealer.
EGR system has an internal leak.	Bring the vehicle to an authorized dealer.

<b>Problem—There Is Coolant in the Engine Oil</b>	
<b>Cause</b>	<b>Remedy</b>
The cylinder head gasket is damaged.	Have an authorized dealer replace the head gasket.
The oil/water heat exchanger is leaking.	Have an authorized dealer replace the heat exchanger.
There is an internal coolant leak.	Bring the vehicle to an authorized dealer for service.

<b>Problem—There Is Foam in the Engine Oil</b>	
<b>Cause</b>	<b>Remedy</b>
The oil level is too low or too high.	Correct the oil level.
The oil has not been changed within the recommended interval.	Change the oil.
The oil is not of the recommended quality.	Change the oil.

<b>Problem—The Engine Oil Pressure Is Low</b>	
<b>Cause</b>	<b>Remedy</b>
The oil pressure gauge and/or sensor is not reading correctly.	Bring the vehicle to an authorized dealer for service.
There is fuel in the oil.	Bring the vehicle to an authorized dealer for service.
The oil filter is clogged.	Replace the filter element.
The oil filter bypass valve is damaged.	Replace the bypass valve.
The oil pump and/or relief valve is damaged.	Have an authorized dealer replace the oil pump.

<b>Problem—The Engine Exhaust Is White</b>	
<b>Cause</b>	<b>Remedy</b>
The fuel is of poor quality.	Add fuel of the right quality.
The intake air preheater is malfunctioning.	Check the intake air preheater, and replace it, if necessary.
The valves are not adjusted properly.	Check the valve lash.

<b>Problem—The Engine Exhaust Is Black</b>	
<b>Cause</b>	<b>Remedy</b>
The air filter and/or intake air system is clogged.	Check the air restriction indicator. Clean the intake air system and replace the air filter if necessary.
The exhaust brake valve is malfunctioning.	Have an authorized dealer check the operation of the valve.
The intake air preheater is malfunctioning.	Check that the heater is not staying on all of the time.
The valves are not adjusted properly.	Check the valve lash.
There is damage to the fuel system: the fuel pump, one or more fuel injectors, or one or more unit pumps are damaged.	Bring the vehicle to an authorized dealer for service.
The charge-air temperature sensor is damaged.	Bring the vehicle to an authorized dealer for service.
There is internal damage to the engine.	Bring the vehicle to an authorized dealer for service.

<b>Problem—The Engine Exhaust Is Blue</b>	
<b>Cause</b>	<b>Remedy</b>
The engine oil level is too high (engine oil is reaching the combustion chamber).	Adjust the oil level, and then have the oil level checked by an authorized dealer.
The turbocharger is leaking oil.	Have an authorized dealer replace the turbocharger
The valve stem seals are loose or damaged.	Have an authorized dealer replace the seals.
The piston rings are worn.	Have an authorized dealer replace the piston rings.

<b>Problem—Engine Brake Performance Is Poor</b>	
<b>Cause</b>	<b>Remedy</b>
The engine brake control switch is damaged.	Replace the switch
The exhaust brake is not operating properly.	Have an authorized dealer check the operation of the valve.
The constant-throttle valves are malfunctioning.	Bring the vehicle to an authorized dealer for service.
Components of the DDEC-ECU and/or DDEC-VCU are damaged.	Bring the vehicle to an authorized dealer for service.

<b>Problem—Cruise Control Is Not Working</b>	
<b>Cause</b>	<b>Remedy</b>
One or more of the cruise control switches are damaged.	Replace the damaged switch.
Components of the DDEC-ECU and/or DDEC-VCU are damaged or not working properly.	Bring the vehicle to an authorized dealer for service.

<b>Problem—The Battery Charge Indicator Light Does Not Come On When the Engine Is Not Running</b>	
<b>Cause</b>	<b>Remedy</b>
The bulb is damaged.	Change the bulb.
The circuit is broken.	Repair the break in the circuit.

<b>Problem—The Battery Charge Indicator Light Comes On When the Engine is Running</b>	
<b>Cause</b>	<b>Remedy</b>
The poly-V belt is too loose.	Check the belt tension; if necessary, have an authorized dealer replace the belt tensioner.
The belt tensioner is damaged.	Have an authorized dealer replace the belt tensioner.
The poly-V belt is worn or damaged.	Replace the belt.
The alternator is damaged (has a damaged rectifier or voltage regulator).	Have an authorized dealer replace the alternator.



## SERVICE PRODUCTS

Use only the DDC recommended lubricants discussed in this section. Additional information is available from any authorized dealer.

Do not use special lubricant additives. None are needed, and the use of additives could affect warranty coverage.

**Important:** Dispose of service products in an environmentally responsible manner. This includes any parts which have been in contact with them (for example, filters). Reclaim them or recycle them, if possible, and be sure to comply with all legal disposal requirements.

### Diesel Fuels

Use only commercially available vehicle diesel fuel. Grades such as marine diesel fuel, heating oil, and others are not permissible.

Do not use fuel additives. Using fuel additives could affect your warranty.

Only low sulfur diesel fuel should be used for EGR engines (sulfur content = 0.05 percent by weight). For non-EGR engines if you are using diesel fuel with a high sulphur content, exceeding 0.5 percent by weight, change the engine oil at shorter intervals. Comply with the instructions in the service manual.

Fuel added from drums or cans could be contaminated. This could lead to malfunctions in the fuel system. Always filter the fuel before adding it to the tank. Ensure there is no water in the fuel.

For information about fuel in cold weather operation, refer to the section "Winter-Grade Diesel Fuel" later in this chapter.

### Flow Improvers

The effectiveness of flow improvers is not guaranteed with all fuels. Comply with the product manufacturer's recommendations. Any authorized dealer can provide information on approved flow improvers.

### Kerosene

Keep the quantity added as low as possible, bearing in mind the outside temperature.

The addition of five percent by volume of kerosene will improve the fuel's resistance to cold by about 1°C (1.8°F). Never add more than 50 percent kerosene to the fuel.

**NOTICE:**

For safety reasons, add the kerosene to the diesel only in the fuel tank. Add the kerosene first, then the diesel. Run the engine for a short time to allow the mixture to reach all parts of the fuel system.

**Engine Oils**

The engine is delivered from the factory filled with an approved engine oil.

**NOTICE:**

The use of non-approved engine oils could affect warranty rights, and cause engine damage.

To ensure long and trouble-free service, it is important to select oil of the correct viscosity and service designation.

**EGR Engines**

Only multigrade oils of American Petroleum Institute (API) service designation PGOS 93K214 or CI-4 Plus quality engine oils will achieve proper performance for the cooled EGR engines. Detroit Diesel POWER GUARD oils meet this specification and are recommended. Look for the service mark printed on the oil container. See Figure 27.

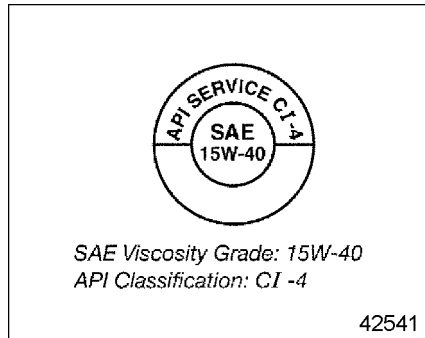

**Figure 27 API Lubricant Service Mark**

When maintenance work is performed, record engine oil changes including details of the brand used, the quality category, and the Society of Automotive Engineers (SAE) viscosity rating of the oil. When topping off, use only engine oils of the correct API designation and SAE rating. Detroit Diesel POWER GUARD oils meet these specifications.

For information about oil in cold weather operation, see the heading "Low-Viscosity Engine Oil" later in this chapter.

## Non-EGR Engines

API CI-4 or CH-4 oils are recommended for use in all non-EGR engines. These oils are intended for engines with open breather systems. Detroit Diesel POWER GUARD oils meet these specifications and are recommended.

## Synthetic Oils

Synthetic oil may be used in MBE900 engines, provided they are of the correct API designation and viscosity, as required for non-synthetic oil.

Synthetic oil offers improved low-temperature flow properties and high-temperature resistance to oxidation. However, it is generally more costly than non-synthetic oil.

Review carefully the product information published by the synthetic oil manufacturer. Performance additive systems often respond differently in synthetic oil. Use of synthetic oil does not change the recommended oil change service interval.

## Coolant

Coolant is a mixture of water and antifreeze. Under normal conditions, it is a mixture of 50 percent water and 50 percent antifreeze, but under extreme cold weather conditions, as much as 60 percent antifreeze can be

added. For reasons of anticorrosion protection and to raise the boiling point, the coolant with a minimum 50% of antifreeze must remain in the cooling system all year round.

Regardless of mileage, replace the coolant every two years since the degree of corrosion protection gradually drops with time.

## Fully-Formulated Antifreeze

Antifreeze approved for use in the MBE900 engine is a mixture of glycol compounds (either ethylene glycol or propylene glycol), and corrosion inhibitors. Antifreeze containing glycol compounds and corrosion inhibitors is known as fully-formulated antifreeze.

Fully-formulated antifreeze has the following properties:

- It protects the radiator and engine from freezing.
- It provides protection against corrosion and cavitation for all components in the cooling system.
- It raises the boiling point of the coolant. This slows the rate of evaporation, avoiding coolant loss at high temperatures.

**Water**

Water containing no additives is not suitable as a coolant, even if no antifreeze protection is needed.

The water used in the coolant must comply with certain requirements, which are not always satisfied by drinking water. If water quality is inadequate, the water must undergo suitable treatment.

The following types of water are preferred for use in coolant:

- Distilled water
- Water purified by reverse osmosis
- De-ionized water

**NOTICE:**

In some areas, tap water can contain high levels of dissolved chlorides, sulfates, magnesium, and calcium, causing scale deposits, sludge deposits and/or corrosion. These deposits can damage the coolant pump and allow the engine to overheat.

**Coolant Specifications**

To avoid damage to the cooling system, use only an approved corrosion-inhibiting antifreeze. Approved antifreeze must be fully-formulated and comply with the requirements of the Truck Maintenance Council (TMC). Coolant specifications are listed in Table 2. Detroit Diesel POWER COOL products meet these specifications and are recommended.

**Coolant Concentration**

When topping off the cooling system after a drop in the coolant level, the concentration of corrosion-inhibiting antifreeze in the coolant must be 50 percent by volume. This affords protection down to a temperature of  $-37^{\circ}\text{C}(-34^{\circ}\text{F})$ . The cooling mixing ratio is listed in Table 3.

Type of Coolant	Requirement
Fully-Formulated Ethylene Glycol	TMC RP-329 Type "A"
Fully-Formulated Propylene Glycol	TMC RP-330 Type "A"
Water plus Corrosion Inhibitors	Temperature Must Not Fall Below $0^{\circ}\text{C}$ ( $32^{\circ}\text{F}$ )

**Table 2 Coolant Specifications**

Antifreeze Protection Down to °C (°F)	Water % by Volume	Corrosion - Inhibiting Antifreeze % by Volume
-37 (-34)	50	50 minimum
-52 (-62)	40	The cooling mix ratio is Max. 60

**Table 3 Coolant Mixing Ratio**

**Important:** If the concentration is too low, there is risk of corrosion/cavitation in the cooling system.

For information about coolant in cold weather operation, see the heading "Winter Coolant Antifreeze Protection" later in this chapter.

**Supplemental Coolant Additives for Fully Formulated Coolant**

The concentrations of some inhibitors will gradually deplete during normal engine operation. SCAs replenish the protection for cooling system components. The coolant must be maintained with the proper concentration of SCA. Detroit Diesel POWER COOL maintenance SCAs are recommended.

**NOTICE:**

Failure to properly maintain coolant with SCA can result in damage to the cooling system and its related components. Conversely, over-concentration of SCA inhibitor can result in poor heat transfer, leading to engine damage. Always maintain concentrations at recommended levels. Do not use traditional SCAs with NOAT coolant.

The proper application of SCA will provide:

- pH control
- Restored inhibitor levels to prevent corrosion
- Water-softening to deter formation of mineral deposits
- Cavitation protection to protect wet sleeve cylinder liners

## Dropout

Excessive amounts of some corrosion inhibitors can cause a gel or crystalline deposit that reduces both heat transfer and coolant flow. This deposit is called "dropout."

Dropout takes the color of the coolant when wet, but becomes a white or gray powder when dry. It can pick up solid particles in the coolant and become gritty. It will cause premature wear of the coolant pump seals and other components of the cooling system.

The wet gel can be removed using an alkaline (non-acid) cleaner containing either sodium nitrite or sodium tetraborate.

If the gel is allowed to dry, it is necessary to disassemble the engine and clean it with a caustic solution, or physically clean the individual components.

## Disposal

Coolants are biologically degradable substances.

When disposing of used coolant, comply with local legal requirements and waste water regulations.

Consult the local water supply authorities to determine the best method of disposal.

A modern engine coolant has complex tasks to perform. Do not allow any

form of "reprocessing" which consists only of mechanical purification.

## Cold Weather Products

Special precautions must be taken during cold weather. To protect your engine, take the following special measures in cold weather:

- Use special cold weather fuel and engine oil.
- Check the concentration of antifreeze in your coolant.
- Take special care of your batteries.

## Winter-Grade Diesel Fuel

At low outside temperatures, paraffin may separate from the diesel and affect its ability to flow freely.

Avoid breakdowns caused by this problem (for example, blocked filters) by using cold-resistant winter-grade diesel fuel with improved low-temperature flow characteristics. In most cases, winter-grade fuel can be used without problems at cold outside temperatures.

If using summer-grade fuel or a less cold-resistant winter grade, a flow improver or kerosene can be added with caution. The amount needed depends on the outside temperature.



**WARNING:**

**FIRE**

---

**To avoid increased risk of a fuel fire, do not mix gasoline and diesel fuel.**

Flow improver or petroleum spirit must be mixed with diesel fuel before its flow characteristics have been adversely affected by paraffin separation. If changes have already been caused by paraffin separation, they can be corrected only by heating the entire fuel system. Do not add anything to cold-resistant winter-grade diesel fuels. The fuel's low-temperature flow characteristics could actually deteriorate with additives.

### Low-Viscosity Engine Oil

When changing the engine oil, estimate the interval before your next oil change. Choose an oil from the SAE viscosity class which corresponds to the outside temperatures anticipated during this period of operation. See Figure 28.

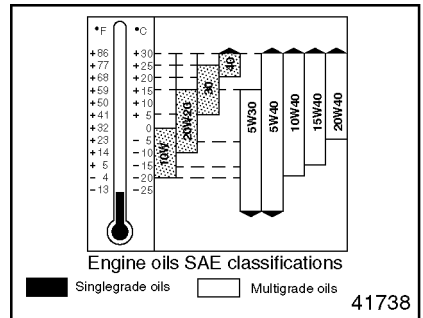

**Figure 28 Engine Oil Temperature Ranges**

### Winter Coolant Antifreeze Protection

Before the temperature dips below freezing, check the concentration of antifreeze in the coolant. If necessary, increase it.

Do not increase the proportion (mixing ratio) of corrosion-inhibiting antifreeze beyond 55 percent by volume (this gives the maximum antifreeze protection). Further increases in the mixing ratio would reduce the level of antifreeze protection and adversely affect the coolant's ability to dissipate heat.

### Batteries

Batteries should receive more frequent maintenance and recharging during the cold season of the year.

Careful maintenance and low current consumption will help to maintain the full battery charge. Starting capacity drops severely in cold weather. For example, at  $-10^{\circ}\text{C}$  ( $14^{\circ}\text{F}$ ) starting capacity is only about 60 percent of normal. If the engine is shut down or out of use for an extended period of time, store the batteries out of the vehicle in a heated area if possible. Ensure good ventilation when recharging.



## TECHNICAL DATA

General technical information is listed in Table 4.

Description	4-Cylinder Engines		6-Cylinder Engines	
	904	924	906	926
Engine Type	Vertical, inline cylinder block with turbocharger and charge-air cooler			
Cooling System	Liquid Circuit			
Combustion Principle	4-Stroke direct-injection diesel			
Number of Cylinders	4		6	
Bore	4.02 in (102 mm)	4.17 in (106 mm)	4.02 in (102 mm)	4.17 in (106 mm)
Stroke	5.11 in (130 mm)	5.35 in (136 mm)	5.11 in (130 mm)	5.35 in (136 mm)
Displacement (total)	259 in <sup>3</sup> (4.25 liters)	262 in <sup>3</sup> (4.8 liters)	389 in <sup>3</sup> (6.37 liters)	439 in <sup>3</sup> (7.2 liters)
Compression Ratio	18.0:1			17.5:1
Starting Speed	Approximately 100 rpm			
Direction of Engine Rotation (viewed from flywheel)	Counterclockwise			
Starter	Electric Motor			
Cold-Start Temperature Limit (Without starting aids and with battery 75% charged)	The engine starts quickly without additional cold start device in temperatures down to -15°C (+5°F). An optional grid heater provides easy starting in extreme temperatures down to -25°C (-13°F). For temperatures below -25°C (-13°F) an optional grid heater with preheating for coolant and lube oil is available.			

**Table 4 General Technical Information**

## Engine Data for EGR Engine

The engine weights are listed in Table 5. The engine dimensions are listed in Table 6. Also see Figure 29 and Figure 30. Coolant and lubricating oil capacities are listed in Table 7

Engine	Engine Dry Weight
4-Cylinder	420 kg (926 lb)
6-Cylinder	560 kg (1235 lb)

**Table 5 Engine Weights**

4-Cylinder	6-Cylinder
A = 1025 mm (40.4 in.)	A = 1219 mm (48 in.)
B = 686 mm (27 in.)	B = 810 mm (31.9 in.)
C = 1000 mm (39.4 in.)	C = 1060 mm (41.7 in.)

**Table 6 Engine Dimensions**

Description	4-Cylinder Engine	6-Cylinder Engine
Coolant Capacity*	Max. 8 L (8.5 qt)	Max. 12.5 L (13.2 qt.)
Lubricating Oil Capacity**	Max. 15.8 L (16.7 qt)	Max. 29 L (30.6 qt)

\*Does not include capacity of cooling system.

\*\*For standard oil pan.

**Table 7 Coolant and Lubricating Oil Capacity**

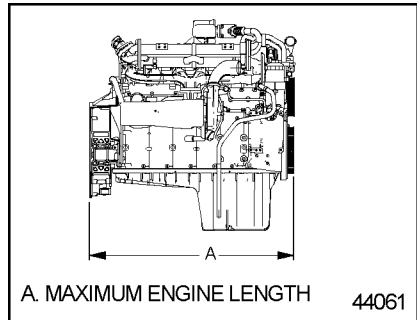

**Figure 29 Engine Measurements (Side View)**

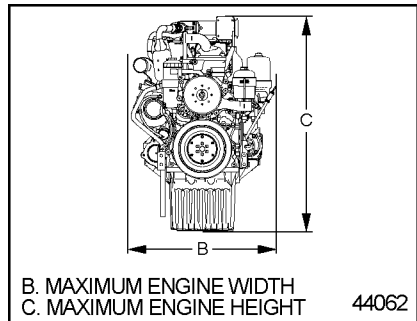

**Figure 30 Engine Measurements (Front View)**

## Engine Data for Non-EGR Engine

The engine weights are listed in Table 8. The engine dimensions are listed in Table 9. Also see Figure 31 and Figure 32. Coolant and lubricating oil capacities are listed in Table 10.

Engine	Engine Dry Weight
4-Cylinder	395 kg (871 lb)
6-Cylinder	530 kg (1169 lb)

**Table 8 Engine Weights**

4-Cylinder	6-Cylinder
A = 1025 mm (40.4 in.)	A = 1219 mm (48.0 in.)
B = 686 mm (27.0 in.)	B = 810 mm (31.9 in.)
C = 925 mm (36.4 in.)	C = 940 mm (37.0 in.)

**Table 9 Engine Dimensions**

Description	4-Cylinder Engine	6-Cylinder Engine
Coolant Capacity*	Max. 8.5 L (9.0 qt.)	Max. 12.5 L (13.2 qt.)
Lubricating Oil Capacity	Max. 15.8 L (16.7 qt)	Max. 29.0 L (30.6 qt)

\*Does not include capacity of cooling system.

\*\*For standard oil pan

**Table 10 Coolant and Lubricating Oil Capacity**

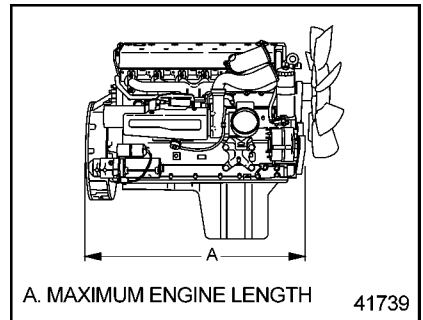

**Figure 31 Engine Measurements (Side View)**

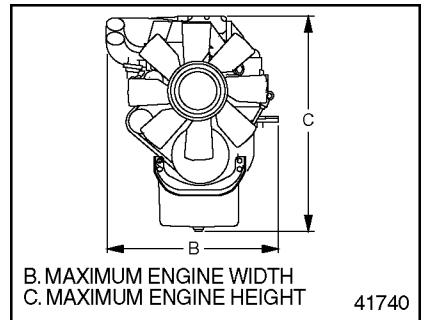

**Figure 32 Engine Measurements (Front View)**

## Testing and Adjusting Values

Valve lash checking and adjustments are listed in Table 11. Engine

Oil Pressure is listed in Table 12. Coolant thermostat conditions are listed in Table 13. Injector pressures are listed in Table 14.

Valve Type	Check For: mm ( in.)	Adjust To: mm ( in.)
Intake	0.30 to 0.60 (0.012 to 0.024)	0.016 (0.40)
Exhaust	0.50 to 0.80 (0.020 to 0.032)	0.60 (0.024)

**Table 11 Valve Lash Checking and Adjustment**

Engine Speed	Minimum Pressure
At idling rpm	50 kPa (7 psi)
At maximum rpm	250 kPa (36 psi)

**Table 12 Engine Oil Pressure**

Condition	Specification
Starts to open	81 to 85°C (177 to 185°F)
Fully open	95°C (203°F)
Minimum lift	8 mm ( 0.3 in.)

**Table 13 Coolant Thermostat**

Opening Pressure	Value in kPa (psi)
Minimum opening pressure	24,497 (3,553)
Maximum opening pressure	25,697 (3,727)

**Table 14 Injector Pressure**

## MAINTENANCE

When performed on a regular basis, changing the engine oil and filters is the least costly way of obtaining safe and reliable vehicle operation. Added benefits and savings occur when you check that the valves, fuel injectors, and oil and cooling circuits are in good working order during oil changes.

The maintenance section of this manual explains when you should change your oil and what to look for when checking for wear or damage.

For additional information, please contact your regional office.

### Scheduled Intervals

All service intervals and maintenance operations are based on the parts and accessories expressly approved for your engine.

The scope and frequency of maintenance work are determined by the engine's operating conditions: severe duty, short haul, long haul or operating hours vs. fuel consumption (oil drain interval only).

Evidence of regular maintenance is essential if a warranty claim has to be submitted.

If optional equipment is installed, be sure to comply with the maintenance requirements for these extra items.

**Important:** If the engine is stored for more than 18 months, the oil must be changed before the engine can be brought into service.

### Maintenance Schedule Types

There are five types of maintenance schedule:

- Schedule I (Severe Service)
- Schedule II (Short Haul)
- Schedule III (Long Haul)
- Operating Hours vs. Fuel Consumption (Oil Drain Interval Only)
- UNIMOG Service Schedule

To determine which schedule to use, find the distance traveled by the vehicle in a year, regardless of vehicle type.

**Severe Service** — Applies to vehicles that annually travel up to 100,000 kilometers (60,000 miles) or that operate under severe conditions. Examples of Severe Service usage include: operation on extremely poor roads or where there is heavy dust accumulation; constant exposure to extreme hot, cold, salt-air, or other extreme climates; frequent short-distance travel; construction-site

operation; city operation (fire truck, garbage truck); or farm operation.

**Short-Haul** — Applies to vehicles that annually travel up to 100,000 kilometers (60,000 miles) and operate under normal conditions. Examples of Short-Haul usage are: operation primarily in cities and densely populated areas; local transport with infrequent freeway travel; or high percentage of stop-and-go travel.

**Long-Haul** — Long Haul (over-the-road transport) is for vehicles that annually travel more than 100,000 kilometers (60,000 miles), with minimal city or stop-and-go operation. Examples of Long-Haul usage are: regional delivery that is mostly freeway miles; interstate transport; or any road operation with high annual mileage.

**Operating Hours vs. Fuel Consumption (Oil Drain Interval Only)** — Operating hours vs. fuel consumption is for operators who want an oil drain interval based on hours of operation instead of miles traveled. See Figure 33.

**UNIMOG** — The UNIMOG engine has long maintenance intervals.

**Maintenance Schedule and Interval Operations** — The three

different schedules of vehicle usage (severe, short haul, and long haul) are listed in Table 15. For each schedule, the appropriate distance interval (in miles and kilometers) is given for performing and repeating each maintenance operation.

The descriptions of all maintenance operations, indicating all maintenance operation sets at which each operation must be performed are listed in Table 15.

**Maintenance Intervals** — The three maintenance interval tables show which maintenance operation must be performed at the actual distances (in miles or kilometers) for each maintenance operation (M1–M3). The schedule of actual distances is based on the intervals listed in Table 15. The UNIMOG maintenance intervals for replacement of fluids and filters are listed by operating hours.

The maintenance interval tables are:

- Maintenance Interval Table, Severe Service (information listed in Table 16)
- Maintenance Interval Table, Short Haul (information listed in Table 17)
- Maintenance Interval Table, Long Haul (information listed in Table 18)

- The UNIMOG maintenance intervals for replacement of fluids and filters are listed in Table 21, Table 22, Table 23, and Table 24.

### **Maintenance Operation Sets —**

Each Maintenance Operations Sets Table (M1 through M3) lists the descriptions of only those maintenance operations that must be performed at that maintenance operation set. Each maintenance operation set is listed in Table 19 and Table 20.

### **Schedule Use**

Before placing your new vehicle in service, determine the correct maintenance intervals that apply to your intended use of the vehicle. Refer to the Maintenance Schedule Table to determine the distance interval at which each maintenance operation must be performed to comply with your vehicle's schedule. A detailed description of maintenance operations can be found later in this section

When the vehicle reaches the actual distance given for an interval, refer to the Maintenance Interval Tables to find the Maintenance Operation Set that applies to that interval. Then perform the maintenance operations listed in the applicable Maintenance Interval Operation Table.

Complete each Maintenance Operation Set at the required interval. For example, when you have completed Maintenance Operation Set M3 under the 16th maintenance number listed in the Maintenance Interval Table, repeat the pattern. For the 17th maintenance, do Maintenance Operation Set M1, under the first maintenance number listed in the Maintenance Interval Table.

### **NOTE:**

For Severe Service, the pattern repeats after 15 maintenance numbers, not 16 (as for Short Haul and Long Haul).

## Maintenance Tables and Graphs

Maintenance Schedule	Maint. Interval Operation	Maintenance Intervals		
		Frequency	Miles	Km
Schedule I (Severe Service) vehicles that annually travel up to 6,000 miles (9,650 km)	Maint. 1 (M1)	every	6,000 (904/906/926)	9,650 (904/906/926)
	Maint. 2 (M2)	every	18,000	29,000
Schedule II (Short Haul) vehicles that annually travel up to 60,000 miles (96,500 km)	Maint. 1 (M1)	every	15,000 (904/906/926)	24,000 (904/906/926)
	Maint. 2 (M2)	every	60,000	96,500
	Maint. 3 (M3)	every	75,000	121,000
Schedule III (Long Haul) vehicles that annually travel more than 60,000 miles (96,500 km)	Maint. 1 (M1)	every	20,000 (904/906/926)	32,000 (904/906/926)
	Maint. 2 (M2)	every	60,000	96,500
	Maint. 3 (M3)	every	80,000	129,000

**Table 15 Maintenance Schedule Table**



Maint. No	Maintenance Interval	Miles	Km
1	M1*	6,000	9,650
2	M1	12,000	18,000
3	M1 and M2	18,000	30,000
4	M1	24,000	40,000
5	M1	30,000	50,000
6	M1 and M2	36,000	60,000
7	M1	42,000	70,000
8	M1	48,000	80,000
9	M1 and M2	54,000	90,000
10	M1	60,000	96,500
11	M1	66,000	110,000
12	M1 and M2	72,000	120,000
13	M1	78,000	130,000
14	M1	84,000	140,000
15	M1 and M2	90,000	150,000

\* 6-cylinder engines use a oil centrifuge filter to meet the above intervals, the cartridge in the centrifuge has the same interval as the primary filter. 4-cylinder engines will not use the oil centrifuge.

**Table 16 Maintenance Intervals for Schedule I, Severe Service**

Maint. No.	Maintenance Interval	Miles	Km
1	M1*	15,000	24,000
2	M1	30,000	48,000
3	M1	45,000	72,000
4	M1 and M2	60,000	96,500
5	M1 and M3	75,000	120,000
6	M1	90,000	144,000
7	M1	105,000	168,000
8	M1 and M2	120,000	192,000
9	M1	135,000	216,000
10	M1 and M3	150,000	241,000
11	M1	165,000	265,000
12	M1 and M2	180,000	289,000
13	M1	195,000	314,000
14	M1	210,000	338,000
15	M1 and M3	225,000	362,000
16	M1, M2 and M3	240,000	386,000

\* 6-cylinder engines use a oil centrifuge filter to meet the above intervals, the cartridge in the centrifuge has the same interval as the primary filter. 4-cylinder engines will not use the oil centrifuge.

**Table 17 Maintenance Intervals for Schedule II, Short Haul**

Maint. No	Maintenance Interval	Miles	Km
1	M1*	20,000	32,000
2	M1	40,000	64,000
3	M1 and M2	60,000	96,500
4	M1 and M3	80,000	128,000
5	M1	100,000	160,000
6	M1 and M2	120,000	193,000
7	M1	140,000	225,000
8	M1 and M3	160,000	257,000
9	M1 and M2	180,000	290,000
10	M1	200,000	322,000
11	M1	220,000	354,000
12	M1, M2 and M3	240,000	386,000
13	M1	260,000	418,000
14	M1	280,000	450,000
15	M1 and M2	300,000	482,000
16	M1 and M3	320,000	515,000

\* 6-cylinder engines use a oil centrifuge filter to meet the above intervals, the cartridge in the centrifuge has the same interval as the primary filter. 4-cylinder engines will not use the oil centrifuge.

**Table 18 Maintenance Intervals for Schedule III, Long Haul**

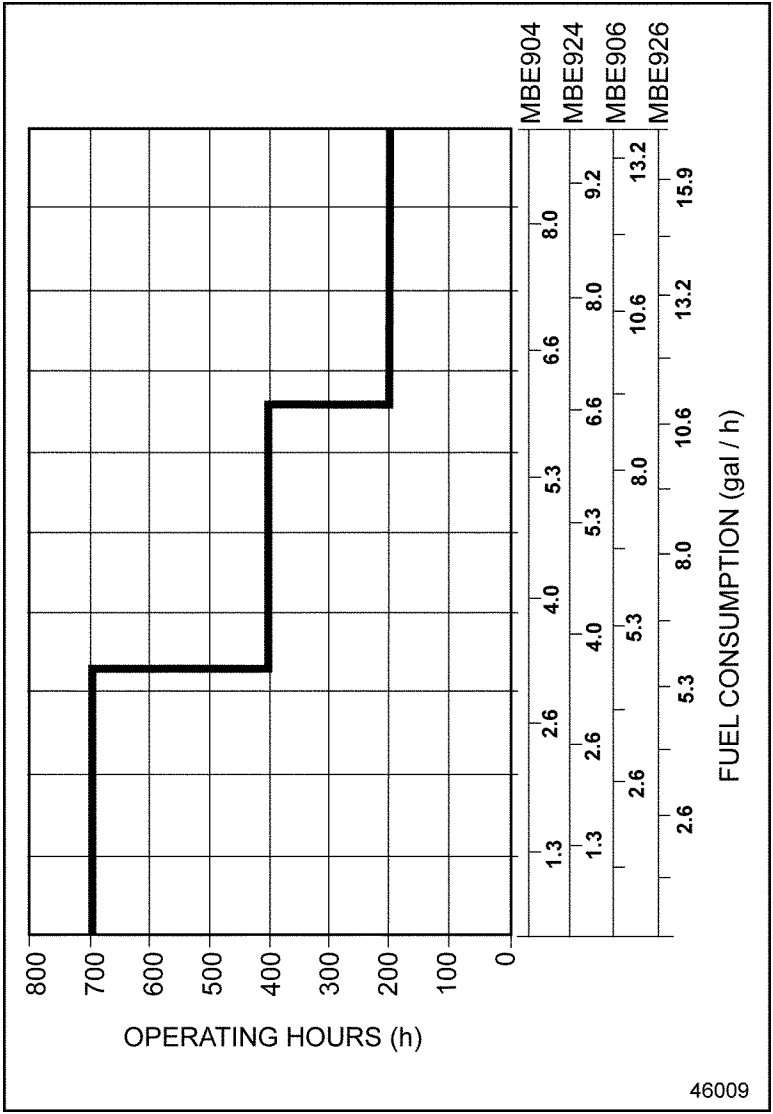

Figure 33 Oil Drain Interval — Operating Hours vs. Fuel Consumption

Operation Description	M1	M2
Engine Inspecting	✓	✓
Fuel Prefilter Element Cleaning	—	✓
Main Fuel Filter Element Changing	—	✓
Valve Checking and Adjusting	—	✓
Engine Oil and Filter Changing, Replace 906 and 926 Oil Centrifuge Cartridge	✓	✓
Coolant Concentration Checking	✓	✓
Coolant Flushing and Changing	—	✓
Cooling System Inspecting	✓	✓

**Table 19 Required Maintenance Operations Sets, Schedule I**

Maintenance Operation Description	M1	M2	M3
Engine Inspecting	—	✓	✓
Valve Lash Checking and Adjusting	—	—	✓
Fuel Prefilter Element Cleaning	—	✓	✓
Main Fuel Filter Element Changing	—	✓	✓
Engine Oil and Filter Changing, Replace 906 and 926 Oil Centrifuge Cartridge	✓	✓	✓
Coolant Concentration Checking	—	✓	✓
Coolant Flushing and Changing	—	—	✓
Cooling System Inspecting	—	✓	✓

**Table 20 Required Maintenance Operations Sets, Schedule II and III**

**NOTE:**

If oil drain intervals are measured by operating hours, an extension of the oil drain interval may be possible. Refer to DDC publication *Lubricating Oil, Fuel and Filters Requirements*

(7SE270) available on the DDC extranet.

**NOTE:**

The engine oil and oil filter **MUST** be changed **EVERY** 200 operating hours.

Component	Maintenance	Operating Hours		
		200	700	1,400
Engine	Change oil and oil filter	✓ Every 200 hours		
Fuel System	Change filter and vent system	—	✓	—
Transmission	Change oil	—	—	—
PTO Transmission	Change oil and oil filter	—	—	—
Axle Gear	Change oil	—	✓	—
Working Hydraulics	Change oil filter	✓	—	—
	Change oil and oil filter	—	—	—

**Table 21 UNIMOG Service Intervals, 200 - 1400 Operating Hours**

Component	Maintenance	Operating Hours		
		2,100	2,800	3,500
Engine	Change oil and oil filter	✓ Every 200 hours		
Fuel System	Change filter and vent system	✓	✓	✓
Transmission	Change oil	✓	—	—
PTO Transmission	Change oil and oil filter	✓	—	—
Axle Gear	Change oil	✓	—	✓
Working Hydraulics	Change oil filter	—	✓	—
	Change oil and oil filter	—	—	—

**Table 22 UNIMOG Service Intervals, 2100 - 3500 Operating Hours**

Component	Maintenance	Operating Hours		
		4,200	4,900	5,600
Engine	Change oil and oil filter	✓ Every 200 hours		
Fuel System	Change filter and vent system	✓	✓	—
Transmission	Change oil	✓	—	—
PTO Transmission	Change oil and oil filter	✓	—	—
Axle Gear	Change oil	—	✓	—
Working Hydraulics	Change oil filter	—	—	—
	Change oil and oil filter	✓	—	—

**Table 23 UNIMOG Service Intervals, 4200 - 5600 Operating Hours**

Component	Maintenance	Operating Hours	
		6,300	7,000
Engine	Change oil and oil filter	✓ Every 200 hours	
Fuel System	Change filter and vent system	✓	✓
Transmission	Change oil	✓	—
PTO Transmission	Change oil and oil filter	✓	—
Axle Gear	Change oil	✓	—
Working Hydraulics	Change oil filter	—	—
	Change oil and oil filter	—	✓

**Table 24 UNIMOG Service Intervals, 6300 - 7000 Operating Hours**

## Required Maintenance Operations

The following sections describe the required maintenance operations listed in Table 19 and 20.

### Engine Inspecting

Inspect the engine as follows:

1. Visually check the engine for signs of leakage. A slight dampness at the sealing points is no cause for alarm.

**NOTE:**

More severe leaks, combined with a continual loss of oil, must be corrected without delay.

2. Visually inspect all lines and hoses. Listen for any sound of leaking. Make sure all pipes and hoses are undamaged, correctly positioned to avoid chafing, and properly secured.

### Valve Lash Checking and Adjusting

**Important:** Adjust the valve lash when the engine is cold. Wait at least 30 minutes after shutdown, even if the engine ran only a short time.

The special tool listed in Table 25 is required for this procedure.

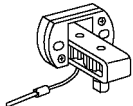
Tool	Description	Manufacturer	Part Number
 <p>PART NUMBER: J-46392</p> <p>41753</p>	<p>Engine Cranking Tool</p>	<p>Kent-Moore</p>	<p>J-46392</p>

**Table 25 Special Tool**



### Gaining Access To The Valves —

Gain access to the valves as follows:

**NOTE:**

Clean the cylinder head cover before removing it.

1. Remove the cylinder head cover (see Figure 34).

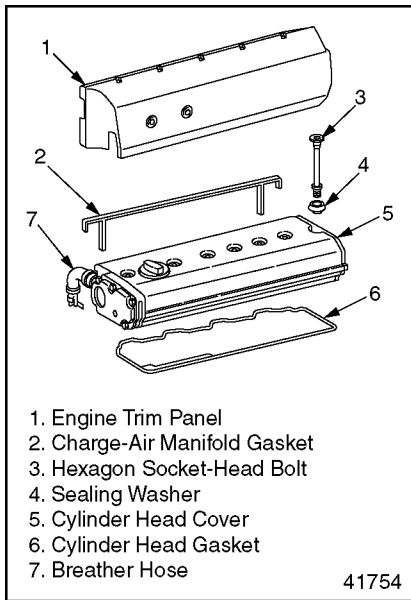

**Figure 34 Cylinder Head Cover**

2. Remove the inspection cover on the timing case.
3. Fit the cranking device listed in Table 25 into the

inspection hole on the timing case (see Figure 35).

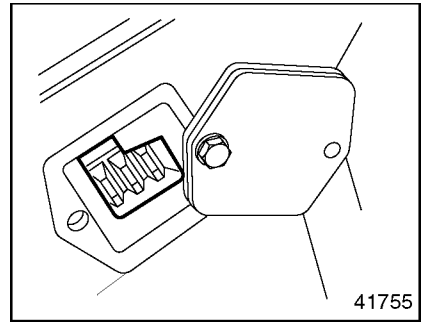

**Figure 35 Inspection Hole in the Timing Case**

4. Select a method for adjusting the valve lash. See Figure 36 for the valve layout on both four- and six-cylinder engines. There are two acceptable methods for adjusting valve lash:
  - In order, according to the timing sequence used for fuel injection ("Method One")
  - By type of valve, depending on crankshaft position ("Method Two")

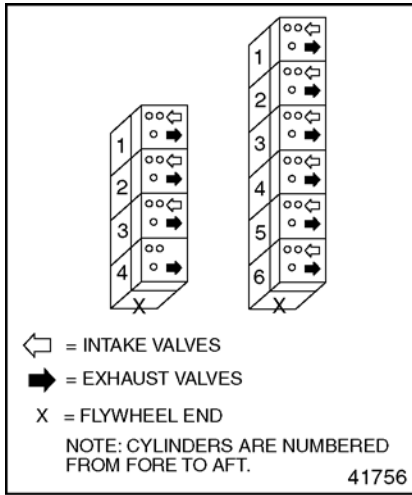

**Figure 36 Cylinder and Valve Layout**

**Method One: Adjust Each Cylinder In Firing Order —**

Method One allows you to adjust each cylinder in the order in which fuel is injected. The crankshaft must

be repositioned after each cylinder is adjusted as listed in Table 26.

1. For each cylinder, use the cranking device to rotate the crankshaft until the piston is exactly at top dead center (TDC) in the compression stroke. The valves must be closed and it must be possible to turn the push rods without effort.

**NOTE:**

When the piston in cylinder #1 is at ignition TDC, the valves of cylinder #6 (cylinder #4 on the four-cylinder engine) will overlap, meaning that both intake and exhaust valves are partially open, and show no measurable play when tested with a feeler gauge.

2. Check each valve and adjust it (if necessary), using the procedures under the headings "Checking Valve Lash" and "Adjusting Valve Lash" in this section.

Engine	Crankshaft Position	Cylinders					
4-Cylinder	Ignition Sequence	1	3	4	2	NA	NA
	Valve Overlap	4	2	1	3	NA	NA
6-Cylinder	Ignition Sequence	1	5	3	6	2	4
	Valve Overlap	6	2	4	1	5	3

**Table 26 Valve Adjustment- Method One**

**Method Two: Adjust All Valves Using Two Crankshaft Positions** — Method two allows

you to adjust all the valves using just two crankshaft positions.

1. Using the cranking device, turn the crankshaft until cylinder #1 is at the ignition TDC position (all valves are closed) and cylinder #6 (cylinder #4 on the four-cylinder engine) is at the valve overlap position (all valves are open).
2. Check the valves listed in Table 27 in the "Ignition TDC" row and adjust them (if necessary), using the procedures under the headings "Checking Valve Lash" and "Adjusting Valve Lash."
3. Using the cranking device, turn the crankshaft until cylinder #6 (cylinder #4 on the four-cylinder engine) is at the ignition TDC position (all valves are closed) and cylinder #1 is at the valve overlap position (valves are open).
4. Using the same procedure, check the valves listed in Table 27 in the "Valve Overlap" row and adjust them (if necessary), using the procedures under the headings "Checking Valve Lash" and "Adjusting Valve Lash."

Engine	Cylinder #1 Crankshaft Position	Cylinders/Valve Types*					
		1	2	3	4	5	6
4-Cylinder	Ignition TDC	I/E	I	E	—	NA	NA
	Valve Overlap	—	E	I	I/E	NA	NA
6-Cylinder	Ignition TDC	I/E	I	E	I	E	—
	Valve Overlap	—	E	I	E	I	I/E

\* I = Intake Valve and E = Exhaust Valve

**Table 27 Valve Adjustment - Method Two**

**Checking Valve Lash** — Check valve lash as follows:

1. For each valve, measure the valve lash with a feeler gauge between the rocker arm and valve stem (exhaust valve) or valve bridge (intake valve). It should be possible to pull the feeler gauge through with no more than light resistance.
2. If the value measured is within the range listed in Table 28 in the "Check For" column, check the next valve.

If the value measured is outside the range listed in Table 28 in the "Check For" column, adjust the valve lash.

**Adjusting Valve Lash** — Adjust valve lash as follows:

1. If adjustment is needed, loosen the locknut. See Figure 37 for intake valves and Figure 38 for exhaust valves. Use the **exact settings** listed in Table 28 in the "Adjust To" column.

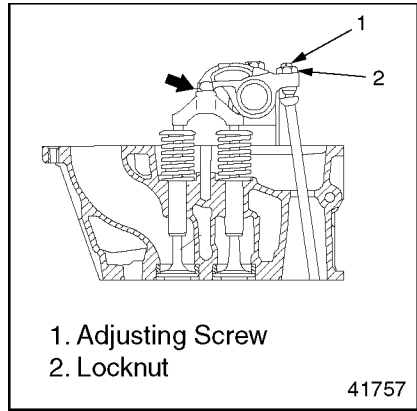

**Figure 37 Intake Valves**

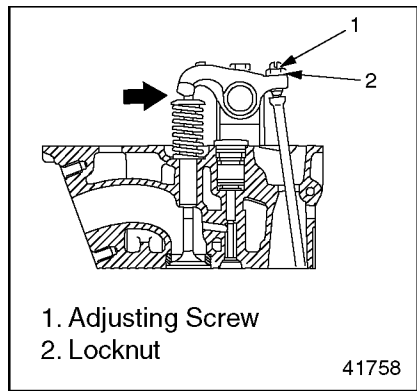

**Figure 38 Exhaust Valves**

Valve Type	Check For:	Adjust to:
Intake	0.30 to 0.60 mm (0.012 to 0.024 in.)	0.40 mm (0.016 in.)
Exhaust	0.50 to 0.80 mm (0.020 to 0.032 in.)	0.60 mm(0.024 in.)

**Table 28 Valve Lash Checking and Adjustment**

2. Turn the adjusting screw until the valve lash is correct using the **exact settings** listed in Table 28. Use the range only for checking adjustment.
3. Tighten the locknut 25 N·m (18 lb·ft).
4. Check the valve lash again. Adjust again if necessary.

### Restoring The Vehicle To Operating Condition — Restore to operating condition as follows:

Restore to operating condition as follows:

1. Install the cylinder head cover. See Figure 39.
2. Remove the cranking device from the inspection hole in the timing case.
3. Replace the end cover on the inspection hole and tighten the bolts 25 N·m (18 lb·ft).

### Fuel Prefilter Element Cleaning

Clean the fuel prefilter element as follows:

1. Open the fuel filler cap to release pressure in the fuel system. Replace and tighten the cap.
2. Clean the outside of the prefilter housing. Keep fuel away from hoses or pipes located beneath the filter. See Figure 40.

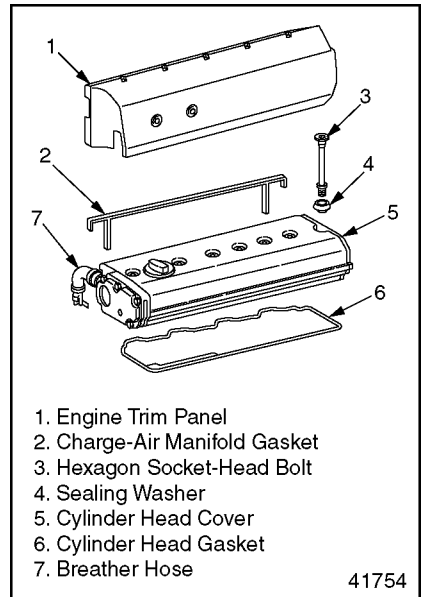

**Figure 39 Cylinder Head Cover**

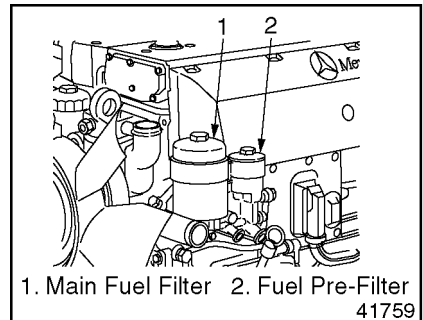

**Figure 40 Fuel Filters**

3. Unscrew the cap on the fuel prefilter. Pull the cap and filter

element out of the prefilter housing. See Figure 41.

4. Clean the cap and the filter element. If the filter element is heavily soiled or damaged, replace it.
5. Check the O-ring on the cap and replace it if necessary.
6. Insert the filter element into the prefilter housing and screw the cap onto the housing. Tighten the cap 25 N·m (18 lb·ft).

7. Bleed the fuel system.

**NOTICE:**

Correct torque on the high pressure lines is critical. Incorrect torques could result in leaks or lack of power due to restricted fuel flow.

- [a] Make sure that all high-pressure lines have been tightened to 25 N·m (18 lb·ft) and all banjo bolts to 40 N·m (30 lb·ft).
- [b] If equipped with a hand pump on the fuel/water separator, work the hand pump 50 times.
- [c] Crank the engine for 30 seconds at a time, but no longer. Before cranking the engine again, wait at least two minutes. The engine should start within four 30-second attempts.

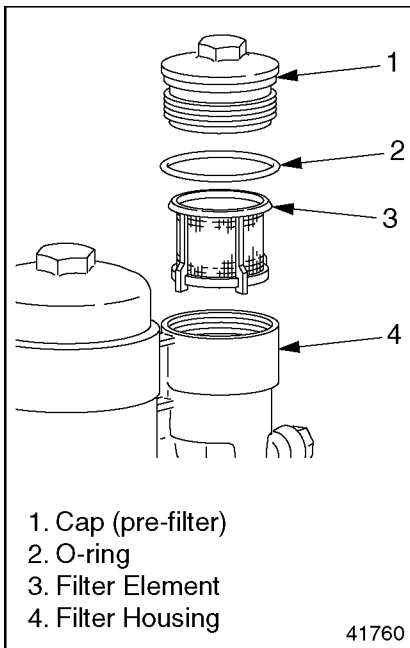

**Figure 41 Fuel Prefilter**

## Main Fuel Filter Element Changing

Change the main fuel filter element as follows:

1. Open the vehicle fuel tank filler cap to release pressure in the fuel system. Replace and tighten the cap.
2. Clean the outside of the fuel filter housing. See Figure 40.
3. Using a 36-mm socket wrench insert, unscrew the cap on the fuel filter and remove it, along with the filter element. Pull both the cap and the filter element a short distance out of the filter housing. See Figure 42. Allow the fuel to drain off the filter into the housing.
4. Remove the cap with the filter element. To release the filter element, twist the lower edge of the filter element to one side.

### NOTICE:

To prevent damage to the filter housing, do not allow dirt to get into the filter housing. Do not empty the dirt collector into the filter case.

5. Pull the dirt collector out of the filter housing using the tabs on either side.

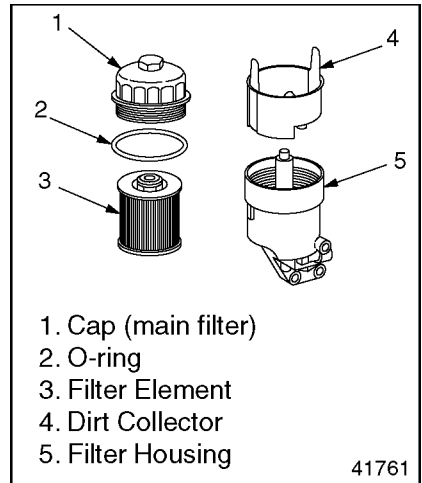

**Figure 42 Main Fuel Filter**

6. Clean the cap and the dirt collector.
7. Replace the O-ring.
8. Install the new filter element in the cap. Make sure the filter element is securely in place.
9. Insert the dirt collector into the filter housing. Make sure the dirt collector is positioned properly in the filter housing.
10. Screw on the cap with the filter element. Tighten the cap 25 N·m (18 lb·ft).

**NOTICE:**

Correct torque on the high pressure lines is critical. Incorrect torques could result in leaks or lack of power due to restricted fuel flow.

11. Bleed the fuel system.
  - [a] Make sure that all high-pressure lines have been tightened to 25 N·m (18 lb·ft)) and all banjo bolts to 40 N·m (30 lb·ft).
  - [b] If equipped with a hand pump on the fuel/water separator, work the hand pump 50 times.
  - [c] Crank the engine for 30 seconds at a time, but no longer. Before cranking the engine again, wait at least two minutes. The engine should start within four 30-second attempts.
12. Start the engine. Check the fuel filter for leaks.

**Engine Oil and Filter Changing**



**WARNING:**

**FIRE**

To avoid injury from fire, keep open flames, sparks, electrical resistance heating elements, or other potential ignition sources away when draining lubrication oil. Do not smoke when draining lubricating oil.

**NOTE:**

Select the SAE class (viscosity) on the basis of the average air temperature for the season. See Figure 43. View the temperature ranges for the various SAE classes as guidelines which can be exceeded for only a short time.

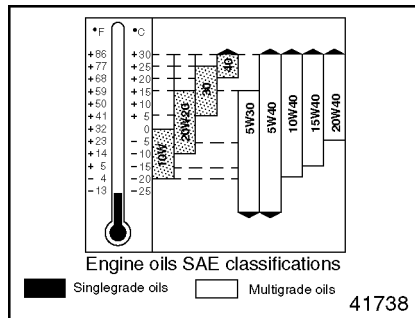

**Figure 43 SAE Oil Viscosity Classes**



To insure the engine is protected and the oil stays clean until the next oil change, use only oils of API classification CI4.

The six-cylinder EGR engines have an oil centrifuge and an oil filter. Non-EGR engines have only an oil filter.

**NOTICE:**

Both the primary lube oil filter (front of engine) and the oil centrifuge cartridge (side of engine) must be replaced at each oil drain interval.

Change the oil filter as follows:

1. Chock the tires, place the transmission in neutral, and set the parking brake.

**NOTE:**

Change the engine oil only when the engine is at an operating temperature of approximately 82°C (180°F).

2. Using a 36-mm socket, unscrew the oil filter cap. See Figure 44.

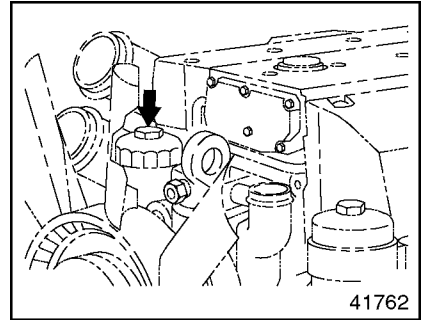

**Figure 44 Oil Filter Cap**

3. Place a suitable receptacle beneath the oil drain plug on the underside of the oil pan. Carefully unscrew the oil drain plug on the oil pan and allow the oil to drain out. See Figure 45. Discard the O-ring on the oil drain plug.

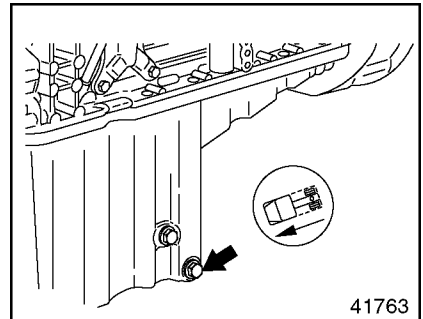

**Figure 45 Engine Oil Drain Plug, Oil Pan**

4. Remove both the filter cap and the filter element. To release the

filter element, twist the lower edge of the filter element to the side. See Figure 46.

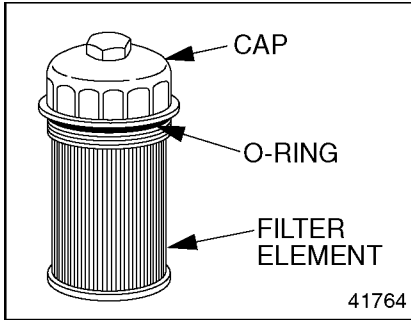

**Figure 46 Cap with Oil Filter Element**

**NOTICE:**

To prevent damage to the filter housing, ensure that no foreign objects get inside it. Do not wipe clean the filter housing.

5. Replace the O-ring on the cap. See Figure 46.
6. Install the new filter into the cap. Make sure the filter element is securely in place.
7. Screw the cap onto the oil filter housing. Tighten the cap 25 N·m (18 lb·ft).
8. Install the oil drain plug, using a new O-ring. Tighten the plug 65 N·m (48 lb·ft).

9. Add new engine oil through the oil fill (see Figure 47).

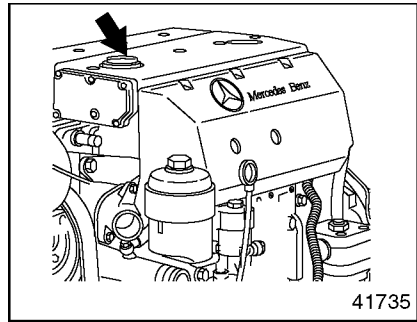

**Figure 47 Oil Fill**



**WARNING:**

**PERSONAL INJURY**

To avoid injury from slipping and falling, immediately clean up any spilled liquids.

**NOTE:**

Engine oil fill capacity with a standard oil pan for the six-cylinder engine is 30.6 quarts (29.0 L). For the four-cylinder engine with a standard oil pan, fill capacity is 16.7 quarts (15.8 L).

10. Fill until the maximum fill level on the oil dipstick has been reached. Do not overfill.

**NOTICE:**

Keep the engine running at idling speed until an oil pressure reading is obtained. If no oil pressure is shown after approximately 10 seconds, stop the engine and determine the cause. Failure to do so could result in engine damage.

11. Start the engine with the accelerator pedal in the idle position. Monitor the oil pressure gauge.
12. Check the filter and oil drain plug for signs of leakage.
13. Stop the engine.
14. Check the oil level again after approximately five minutes. If necessary, add oil up to the maximum fill level on the oil dipstick. Do not overfill.

**Oil Centrifuge**

The MBE six-cylinder engines (906/926) have an oil centrifuge.

**NOTICE:**

Both the primary lube oil filter (front of engine) and the oil centrifuge cartridge (side of engine) must be replaced at each oil drain interval.

Change the oil centrifuge cartridge as follows:

1. Remove the cover of the oil centrifuge. See Figure 48.

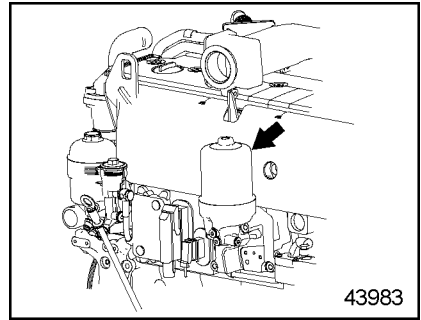

**Figure 48 Oil Centrifuge**

2. Lift out the dirty cartridge and replace it with a clean one (see Figure 49).

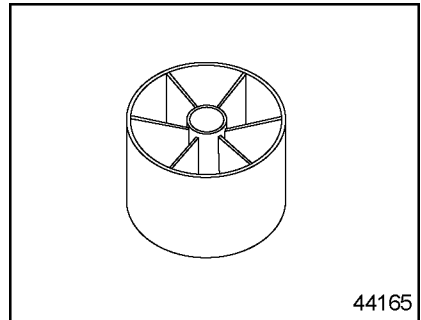

**Figure 49 Centrifuge Cartridge**

3. Replace the centrifuge cover, tighten the cap 40 Nm (30 lb-ft).

## Coolant Concentration Checking

Check coolant concentration as follows:

 <b>WARNING:</b> <b>HOT COOLANT</b>
<p><b>To avoid scalding from the expulsion of hot coolant, never remove the cooling system pressure cap while the engine is at operating temperature. Wear adequate protective clothing (face shield, rubber gloves, apron, and boots). Remove the cap slowly to relieve pressure.</b></p>

1. Open the cap on the surge tank slowly, to allow excess pressure to escape. Set the cap aside.

**NOTE:**

Check and correct the coolant level only when the coolant temperature is below 50°C (122°F).

2. Before adding coolant, use a suitable tester to check the concentration of corrosion-inhibiting antifreeze. If the concentration is lower than 50% by volume, drain coolant/add antifreeze until the concentration is correct. The coolant mixing ratio is listed in Table 29.

**NOTE:**

Concentrations of more than 55% by volume should not be used, as this is the level which affords the maximum antifreeze protection, down to -45°C (-49°F). Higher concentrations adversely affect heat dissipation.

Antifreeze Protection Down to°C (°F)	Water Percentage by Volume	Corrosion-Inhibiting Antifreeze Percentage by Volume
-37 (-347)	50	50
-45 (-49)	45	Maximum 55

**Table 29 Coolant Mixing Ratio**

<b>NOTICE:</b>
<p>If the concentration of antifreeze is too low, there is a risk of corrosion or cavitation in the cooling system.</p>

**NOTE:**

When topping off, use only a pre-prepared coolant mixture containing a 50% concentration

by volume of corrosion-inhibiting antifreeze.

3. Check the coolant level and add more coolant if necessary.
4. Close and tighten the cap on the surge tank.

## Coolant Flushing and Changing

 <p><b>WARNING:</b> <b>HOT COOLANT</b></p>
<p>To avoid scalding from the expulsion of hot coolant, never remove the cooling system pressure cap while the engine is at operating temperature. Wear adequate protective clothing (face shield, rubber gloves, apron, and boots). Remove the cap slowly to relieve pressure.</p>

Flush and change the coolant as follows:

1. Open the cap on the surge tank slowly, to allow excess pressure to escape. Set the cap aside.
2. Open the water regulating valve for the heating system.
3. Drain the coolant from the engine. See Figure 50. Coolant system capacity is listed in Table 30.

- [a] Place a receptacle underneath the coolant drain plug. Choose one that is large enough to hold the expected quantity of coolant.

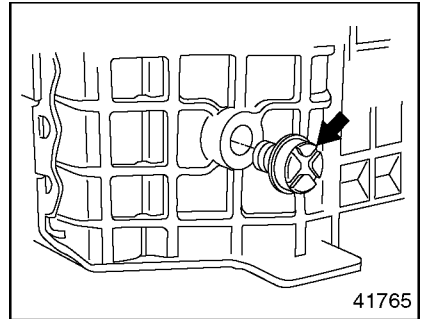

**Figure 50 Coolant Drain Plug**

**NOTE:**

Make sure the coolant can flow unobstructed into the receptacle.

- [b] Open the coolant drain plug on the bottom of the radiator.
4. Flush the radiator.

<b>NOTICE:</b>
<p>When flushing the radiator, do not apply more than 140 kPa (20 psi) air pressure. Excessive pressure can damage the radiator or heater core.</p>

- [a] Attach a flushing gun nozzle to the radiator outlet.

[b] Run water in until the radiator is full.

intermittently to help dislodge sediment buildup in the core.

 <b>WARNING:</b> <b>EYE INJURY</b>
<p><b>To avoid injury from flying debris when using compressed air, wear adequate eye protection (face shield or safety goggles) and do not exceed 276 kPa (40 psi) air pressure.</b></p>

5. Drain the radiator, and flush the radiator until clean water flows from the radiator. Remove the flushing gun.
6. When the coolant has drained, install the coolant drain plug on the radiator.
7. Add coolant in the specified concentration until the maximum mark on the surge tank is reached. Coolant system capacity is listed in Table 30.

[c] Apply no more than 140 kPa (20 psi) air pressure

Description	4-Cylinder	6-Cylinder
<i>Engine Coolant Capacity (all vehicles) L (Qt)</i>		
Engine capacity	8 (8.5)	12 (12.7)
<i>Business Class Coolant System Capacity L (Qt)</i>		
Total capacity	19.8 (21)	23.6 (25)
Antifreeze quantity at 50%	9.9 (10.5)	11.8 (12.5)
Antifreeze quantity at 55%	10.8 (11.5)	13.1 (13.8)

**Table 30 Coolant System Capacity**

8. Start the engine and run it for about one minute at varying speeds to release air pockets in the cooling system. Make sure the heater valve is still open. Check the coolant level and add more coolant if necessary.
9. Shut down the engine.
10. Add coolant if necessary.

## Cooling System Inspecting



**To avoid scalding from the expulsion of hot coolant, never remove the cooling system pressure cap while the engine is at operating temperature. Wear adequate protective clothing (face shield, rubber gloves, apron, and boots). Remove the cap slowly to relieve pressure.**

dirt or debris. Make sure the fins are not damaged, and straighten them if necessary.

### NOTE:

Before doing this inspection, make sure to do either maintenance operation, "Coolant Concentration Checking," or maintenance operation, "Coolant Flushing and Changing."

Inspect the cooling system as follows:

1. Inspect the radiator, the condenser, the coolant pump, the engine oil cooler, the freeze plugs, and the heat exchanger for damage and leaks.
2. Check all pipes and hoses in the cooling system for damage and leaks. Make sure all pipes and hoses are properly positioned to avoid chafing, and are securely fastened.
3. Check the outside of the radiator and condenser for blockage by

## CUSTOMER ASSISTANCE

The satisfaction and good will of the owners of Detroit Diesel engines are of primary concern to Detroit Diesel

Corporation and its distributor/dealer organizations.

### NAFTA ON-HIGHWAY SERVICE REGIONS



d000030P



**DDC NORTH AMERICAN NAFTA ON-HIGHWAY OFFICES**

**EASTERN REGION 1**

**Suwanee, Georgia**  
3325 Paddocks Parkway  
Suwanee, GA 30024  
Telephone: 678-341-6100  
Fax: 678-341-6150

**WESTERN REGION 1**

**Irvine, California**  
7700 Irvine Center, Suite 275  
Irvine, CA 92618  
Telephone: 949-753-7710  
Fax: 949-753-7711

**CANADIAN REGION**

**London, Ontario**  
Detroit Diesel of Canada, Ltd.  
150 Dufferin Ave., Suite 701  
London, ON N5A 5N6  
Phone: 519-661-0149  
Fax: 519-661-0171

**EASTERN REGION 2**

**Detroit, Michigan**  
13400 Outer Drive West  
Detroit, MI 48239-4001  
Telephone: 313-592-5420  
Fax: 313-592-5887

**WESTERN REGION 2**

**Irvine, California**  
7700 Irvine Center, Suite 275  
Irvine, CA 92618  
Telephone: 949-753-7710  
Fax: 949-753-7711

**MTU DETROIT DIESEL OFF-HIGHWAY SALES AND  
CUSTOMER ASSURANCE CENTERS**

**CONSTRUCTION, INDUSTRIAL  
AND MINING SALES (BX7)**

13400 Outer Drive, West  
Detroit, MI 48239-4001  
Phone: 313-592-5608  
Fax: 313-592-5625

**MARINE SALES (BX6)**

13400 Outer Drive, West  
Detroit, MI 48239-4001  
Phone: 313-592-7806  
Fax: 313-592-5137

**POWERGEN AND OIL FIELD SALES  
(BX11)**

13400 Outer Drive, West  
Detroit, MI 48239-4001  
Phone: 313-592-5708  
Fax: 313-592-5158

**GOVERNMENT SALES (BX9)**

13400 Outer Drive, West  
Detroit, MI 48239-4001  
Phone: 313-592-5875  
Fax: 313-592-5158

**CUSTOMER ASSURANCE (M24)**

13400 Outer Drive, West  
Detroit, MI 48239-4001  
Phone: 313-592-5550  
Fax: 313-592-5717

**DDC INTERNATIONAL REGIONAL OFFICE LOCATIONS**

**DETROIT DIESEL DISTRIBUTION  
CENTER B.V. (On/Off-Highway)  
The Netherlands**

Ridderpoort 9  
2984 Ridderkerk  
The Netherlands  
Phone: (31) 180-442-900  
Fax: (31) 180-462-062

**LATIN AMERICAN REGION  
(Off-Highway)  
Miami, Florida**

2277 N.W. 14th Street  
Latin America Building  
Miami, FL 33125-0068  
Phone: 305-637-1555  
Fax: 305-637-1580

**MTU DETROIT DIESEL AUSTRALIA  
PTY. LTD. (On/Off-Highway)**

**Victoria – Melbourne**  
488 Blackshaws Road  
Altona North, Victoria. 3025  
Australia  
Phone: (61) 3 9243-9292  
Fax: (61) 3 9243-9271

**MTU ASIA PTE. LTD. (Off-Highway)  
Singapore**

No. 1 Benoi Place  
Singapore 629923  
Phone: (65) 6861-5922  
Fax: (65) 6861-3615 Sales Marine,  
Rail, C & I, Electronics  
Fax: (65) 6860-9959 Sales  
PowerGen, Defense

**MEXICO (On/Off-Highway)**

Detroit Diesel Allison de Mexico, S.A.  
Av. Santa Rosa 58  
Col. Ampliacion Norte  
San Juan Ixtacala, Tlanepantla  
C.P. 54160, Edo de Mexico  
Phone: 52 55-5333-1803  
Fax: 52 55-5333-1875

## Working with DDC Service Outlets

As the owner of a Detroit Diesel product you have a complete network of over 1,000 Detroit Diesel service outlets in the U.S. and Canada, plus many outlets worldwide that are prepared to meet your parts and service needs:

- Service by trained personnel
- Sales teams to help determine your specific power requirements
- In many areas, emergency service 24 hours a day
- Complete parts support including reliabilt® remanufactured parts
- Product information and literature

We recognize however, that despite the best intentions of everyone concerned, misunderstandings may occur. Normally, any situation that arises in connection with the sale, operation, or service of your product will be handled by the authorized service outlet in your area (in the U.S. and Canada check the Yellow Pages or service locator at [www.detroitdiesel.com](http://www.detroitdiesel.com) for the Detroit Diesel service outlet nearest you).

To further assure your complete satisfaction, we have developed the following procedure to use if you have a problem that has not been handled satisfactorily.

### Step One

Discuss your problem with a member of management from the authorized service outlet. Frequently, complaints are the result of a breakdown in communication and can quickly be resolved by a member of management. If you have already discussed the problem with the Sales or Service Manager, contact the General Manager. If your complaint originates with a dealer, explain the matter to a management member of the distributorship with whom the dealer has his service agreement.

### Step Two

When it appears that your problem cannot readily be resolved at the distributor level without additional assistance, contact the Detroit Diesel Regional Product Support or Operations Manager responsible for your local distributor. You will be assisted by a member of the Manager's staff, depending upon the nature of your problem.

Prior to this contact, have the following information available:

- Engine model and serial number\*
- Name and location of authorized service outlet
- Type and make of equipment

- Engine delivery date and accumulated miles or hours of operation
- Nature of problem
- Chronological summary of engine's history

### **Step Three**

If you are still not satisfied, present the entire matter in writing or by phone to:

**Sr. Vice President, Parts, Service  
and Customer Assurance**

Detroit Diesel Corporation  
13400 Outer Drive, West  
Detroit, Michigan 48239-4001  
Phone: 1-313-592-5000  
Fax: 1-313-592-7244

When contacting the regional or home office, please keep in mind that ultimately your problem will likely be resolved at the distributorship or dealership, utilizing their facilities, equipment, and personnel. Therefore, it is suggested that you first follow the previously mentioned steps in sequence when experiencing a problem.

## LIMITED WARRANTY ON NEW DETROIT DIESEL MBE 900 ENGINES USED IN ON-HIGHWAY VEHICLE APPLICATIONS

### Terms of Coverage

#### Uses

This warranty applies to the first retail purchaser and subsequent owners during the WARRANTY PERIOD of new Detroit Diesel MBE900 Engines (referred to as Engine) manufactured by Detroit Diesel Corporation and/or supplied by Detroit Diesel Corporation or Detroit Diesel of Canada Limited (which are collectively referred to as DDC) for use in on-highway vehicle applications operated in the United States or Canada.

#### Defects

This warranty covers Engine REPAIRS to correct any malfunction occurring during the WARRANTY PERIOD resulting from defects in material or workmanship.

#### Repairs

To obtain warranty repairs, you must request the needed repairs within the WARRANTY PERIOD from an authorized DDC service outlet. Only new genuine parts or remanufactured parts or components supplied or approved by DDC will be used. DDC

may, at its discretion, replace rather than repair components. A reasonable time must be allowed to perform the warranty repair after taking the engine to the authorized service outlet. The owner is responsible for the percentage of repair costs shown in the warranty period chart. Repairs will be performed during normal business hours.

#### Warranty Period

The WARRANTY PERIOD begins on the date the engine is delivered to the first retail purchaser or put in use prior to sale at retail, whichever date occurs first, and ends at the time or mileage/kilometer limits shown in the WARRANTY PERIOD chart.

Warranty Period				
Item	Warranty Limitations (Whichever Occurs First)		Repair Charges to be Paid by Owner	
	Months	Miles/ Kilometers	Parts	Labor
Engine	0-36	0-150,000 mi 0-240,000 km	No Charge	No Charge
Accessories	0-24	0-100,000 mi 0-160,000 km	No Charge	No Charge

**Table 31 Warranty Period Chart — On-highway Vehicle Applications**

**Like Replacement Engine**

Engine(s) supplied by DDC as a replacement for an engine still under warranty will assume the identity of the engine being replaced and be entitled to the remaining warranty coverage.

**Service Supplies**

The cost of service supplies such as coolant, oil and filters which are not reusable due to needed warranty repairs is covered by this warranty.

**Engine Removal and Reinstallation**

Reasonable labor costs for engine removal and reinstallation, when necessary to make a warranty repair, are covered by this warranty.

**This Warranty Does Not Cover:**

**Repairs Due to Accidents, Misuse, Storage Damage, Negligence or Certain Modifications**

Repairs due to an accident, misuse, misapplication, storage damage, negligence or modification exceeding DDC specifications are not covered by this warranty.

*LIMITED WARRANTY ON NEW DETROIT DIESEL MBE 900 ENGINES USED  
IN ON-HIGHWAY VEHICLE APPLICATIONS*

---

**Maintenance**

DDC is not responsible for the cost of maintenance or repairs due to lack of performance of required maintenance services as recommended by DDC, or the failure to use fuel, oil, lubricants and coolant meeting DDC-recommended specifications. Performance of the required maintenance and use of proper fuel, oil, lubricants and coolant are the responsibility of the owner.

**Incidental or Consequential Damages**

Detroit Diesel Corporation is not responsible for incidental or consequential costs or expenses which the owner may incur as a result of a malfunction or failure covered by this warranty, such as communication expenses, meals, lodging, overtime, towing, loss of use of the engine or vehicle (“downtime”), loss of time, inconvenience, cargo loss or damage, and other similar costs and expenses.

**Other Limitations**

Performance of REPAIRS is the exclusive Owner's remedy under this warranty. Detroit Diesel Corporation does not authorize any person to assume or create for it any other obligation or liability in connection with the engine or the accessories.

THIS WARRANTY AND THE EMISSIONS CONTROL WARRANTY ARE THE ONLY WARRANTIES APPLICABLE TO THE ENGINE AS USED IN ON-HIGHWAY VEHICLE APPLICATIONS. DETROIT DIESEL CORPORATION MAKES NO OTHER WARRANTIES EXPRESS OR IMPLIED, INCLUDING ANY IMPLIED WARRANTY OF MERCHANTABILITY OR FITNESS FOR A PARTICULAR PURPOSE. DETROIT DIESEL CORPORATION SHALL NOT BE LIABLE FOR ANY INCIDENTAL OR CONSEQUENTIAL DAMAGES AS DESCRIBED ABOVE.

Some states do not allow the limitation of how long this warranty may last or the limitation or exclusion of incidental or consequential damages, so the above may not apply to you. This warranty gives you specific legal rights, and you may also have other rights which may vary from state to state.



## LIMITED WARRANTY ON NEW DETROIT DIESEL MBE 900 ENGINES USED IN SCHOOL BUS APPLICATIONS

### Terms of Coverage

#### Uses

This warranty applies to the first retail purchaser and subsequent owners during the WARRANTY PERIOD of new Detroit Diesel MBE900 Engines (referred to as Engine) manufactured by Detroit Diesel Corporation and/or supplied by Detroit Diesel Corporation or Detroit Diesel of Canada Limited (which are collectively referred to as DDC) for use in school bus applications operated in the United States or Canada.

#### Defects

This warranty covers Engine REPAIRS to correct any malfunction occurring during the WARRANTY PERIOD resulting from defects in material or workmanship.

#### Repairs

To obtain warranty repairs, you must request the needed repairs within the WARRANTY PERIOD from an authorized DDC service outlet. Only new genuine parts or remanufactured parts or components supplied or approved by DDC will be used. DDC may, at its discretion, replace rather

than repair components. A reasonable time must be allowed to perform the warranty repair after taking the engine to the authorized service outlet. The owner is responsible for the percentage of repair costs shown in the warranty period chart. Repairs will be performed during normal business hours.

#### Warranty Period

The WARRANTY PERIOD begins on the date the engine is delivered to the first retail purchaser or put in use prior to sale at retail, whichever date occurs first, and ends at the time or mileage/kilometer limits listed in Table 32, the WARRANTY PERIOD chart.

LIMITED WARRANTY ON NEW DETROIT DIESEL MBE 900 ENGINES USED  
IN SCHOOL BUS APPLICATIONS

Warranty Period				
Item	Warranty Limitations (Whichever Occurs First)		Repair Charges to be Paid by Owner	
	Months	Miles/ Kilometers	Parts	Labor
Engine	0-60	0-150,000 mi 0-240,000 km	No Charge	No Charge
Accessories	0-24	0-100,000 mi 0-160,000 km	No Charge	No Charge

**Table 32 Warranty Period Chart — School Bus Applications**

### Service Supplies

The cost of service supplies such as coolant, oil and filters which are not reusable due to needed warranty repairs is covered by this warranty.

### Like Replacement Engine

Engine(s) supplied by DDC as a replacement for an engine still under warranty will assume the identity of the engine being replaced and be entitled to the remaining warranty coverage.

### Engine Removal and Reinstallation

Reasonable labor costs for engine removal and reinstallation, when necessary to make a warranty repair, are covered by this warranty.

### This Warranty Does Not Cover:

#### Repairs Due to Accidents, Misuse, Storage Damage, Negligence or Certain Modifications

Repairs due to an accident, misuse, misapplication, storage damage, negligence or modification exceeding DDC specifications are not covered by this warranty.

## **Maintenance**

DDC is not responsible for the cost of maintenance or repairs due to lack of performance of required maintenance services as recommended by DDC, or the failure to use fuel, oil, lubricants and coolant meeting DDC-recommended specifications. Performance of the required maintenance and use of proper fuel, oil, lubricants and coolant are the responsibility of the owner.

## **Incidental or Consequential Damages**

Detroit Diesel Corporation is not responsible for incidental or consequential costs or expenses which the owner may incur as a result of a malfunction or failure covered by this warranty, such as communication expenses, meals, lodging, overtime, towing, loss of use of the engine or vehicle ("downtime"), loss of time, inconvenience, cargo loss or damage, and other similar costs and expenses.

## **Other Limitations**

Performance of REPAIRS is the exclusive Owner's remedy under this warranty. Detroit Diesel Corporation does not authorize any person to assume or create for it any other obligation or liability in connection with the engine or the accessories.

THIS WARRANTY AND THE EMISSIONS CONTROL WARRANTY ARE THE ONLY WARRANTIES APPLICABLE TO THE ENGINE AS USED IN SCHOOL BUS APPLICATIONS. DETROIT DIESEL CORPORATION MAKES NO OTHER WARRANTIES EXPRESS OR IMPLIED, INCLUDING ANY IMPLIED WARRANTY OF MERCHANTABILITY OR FITNESS FOR A PARTICULAR PURPOSE. DETROIT DIESEL CORPORATION SHALL NOT BE LIABLE FOR ANY INCIDENTAL OR CONSEQUENTIAL DAMAGES AS DESCRIBED ABOVE.

Some states do not allow the limitation of how long this warranty may last or the limitation or exclusion of incidental or consequential damages, so the above may not apply to you. This warranty gives you specific legal rights, and you may also have other rights which may vary from state to state.

## LIMITED WARRANTY ON NEW DETROIT DIESEL MBE 900 ENGINES USED IN FIRE TRUCK OR CRASH VEHICLE APPLICATIONS

### Terms of Coverage

#### Uses

This warranty applies to the first retail purchaser and subsequent owners during the WARRANTY PERIOD of new Detroit Diesel MBE900 Engines (referred to as Engine) manufactured by Detroit Diesel Corporation and/or supplied by Detroit Diesel Corporation or Detroit Diesel of Canada Limited (which are collectively referred to as DDC) for use in fire truck or crash vehicle applications operated in the United States or Canada.

#### Defects

This warranty covers Engine REPAIRS to correct any malfunction occurring during the WARRANTY PERIOD resulting from defects in material or workmanship.

#### Repairs

To obtain warranty repairs, you must request the needed repairs within the WARRANTY PERIOD from an authorized DDC service outlet. Only new genuine parts or remanufactured parts or components supplied or approved by DDC will be used. DDC

may, at its discretion, replace rather than repair components. A reasonable time must be allowed to perform the warranty repair after taking the engine to the authorized service outlet. The owner is responsible for the percentage of repair costs shown in the warranty period chart. Repairs will be performed during normal business hours.

#### Warranty Period

The WARRANTY PERIOD begins on the date the engine is delivered to the first retail purchaser or put in use prior to sale at retail, whichever date occurs first, and ends at the time or mileage/kilometer limits listed in Table 33, the WARRANTY PERIOD chart.

Warranty Period				
Item	Warranty Limitations (Whichever Occurs First)		Repair Charges to be Paid by Owner	
	Months	Miles/ Kilometers	Parts	Labor
Engine	0-60	0-150,000 mi 0-240,000 km	No Charge	No Charge
Accessories	0-24	0-100,000 mi 0-160,000 km	No Charge	No Charge

**Table 33 Warranty Period Chart — Fire Truck/Crash Vehicle Applications**

**Like Replacement Engine**

Engine(s) supplied by DDC as a replacement for an engine still under warranty will assume the identity of the engine being replaced and be entitled to the remaining warranty coverage.

**Service Supplies**

The cost of service supplies such as coolant, oil and filters which are not reusable due to needed warranty repairs is covered by this warranty.

**Engine Removal and Reinstallation**

Reasonable labor costs for engine removal and reinstallation, when necessary to make a warranty repair, are covered by this warranty.

**This Warranty Does Not Cover:**

**Repairs Due to Accidents, Misuse, Storage Damage, Negligence or Certain Modifications**

Repairs due to an accident, misuse, misapplication, storage damage, negligence or modification exceeding DDC specifications are not covered by this warranty.

*LIMITED WARRANTY ON NEW DETROIT DIESEL MBE 900 ENGINES USED  
IN FIRE TRUCK OR CRASH VEHICLE APPLICATIONS*

---

**Maintenance**

DDC is not responsible for the cost of maintenance or repairs due to lack of performance of required maintenance services as recommended by DDC, or the failure to use fuel, oil, lubricants and coolant meeting DDC-recommended specifications. Performance of the required maintenance and use of proper fuel, oil, lubricants and coolant are the responsibility of the owner.

**Incidental or Consequential Damages**

Detroit Diesel Corporation is not responsible for incidental or consequential costs or expenses which the owner may incur as a result of a malfunction or failure covered by this warranty, such as communication expenses, meals, lodging, overtime, towing, loss of use of the engine or vehicle (“downtime”), loss of time, inconvenience, cargo loss or damage, and other similar costs and expenses.

**Other Limitations**

Performance of REPAIRS is the exclusive Owner's remedy under this warranty. Detroit Diesel Corporation does not authorize any person to assume or create for it any other obligation or liability in connection with the engine or the accessories.

THIS WARRANTY AND THE EMISSIONS CONTROL WARRANTY ARE THE ONLY WARRANTIES APPLICABLE TO THE ENGINE AS USED IN FIRE TRUCK OR CRASH VEHICLE APPLICATIONS. DETROIT DIESEL CORPORATION MAKES NO OTHER WARRANTIES EXPRESS OR IMPLIED, INCLUDING ANY IMPLIED WARRANTY OF MERCHANTABILITY OR FITNESS FOR A PARTICULAR PURPOSE. DETROIT DIESEL CORPORATION SHALL NOT BE LIABLE FOR ANY INCIDENTAL OR CONSEQUENTIAL DAMAGES AS DESCRIBED ABOVE.

Some states do not allow the limitation of how long this warranty may last or the limitation or exclusion of incidental or consequential damages, so the above may not apply to you. This warranty gives you specific legal rights, and you may also have other rights which may vary from state to state.

## LIMITED WARRANTY ON NEW DETROIT DIESEL MBE 900 ENGINES USED IN UNIMOG APPLICATIONS

### Terms of Coverage

#### Uses

This warranty applies to the first retail purchaser and subsequent owners during the WARRANTY PERIOD of new Detroit Diesel MBE900 Engines (referred to as Engine) manufactured by Detroit Diesel Corporation and/or supplied by Detroit Diesel Corporation or Detroit Diesel of Canada Limited (which are collectively referred to as DDC) for use in UNIMOG applications operated in the United States or Canada.

#### Defects

This warranty covers Engine REPAIRS to correct any malfunction occurring during the WARRANTY PERIOD resulting from defects in material or workmanship.

#### Repairs

To obtain warranty repairs, you must request the needed repairs within the WARRANTY PERIOD from an authorized DDC service outlet. Only new genuine parts or remanufactured parts or components supplied or approved by DDC will be used. DDC may, at its discretion, replace rather

than repair components. A reasonable time must be allowed to perform the warranty repair after taking the engine to the authorized service outlet. The owner is responsible for the percentage of repair costs shown in the warranty period chart. Repairs will be performed during normal business hours.

#### Warranty Period

The WARRANTY PERIOD begins on the date the engine is delivered to the first retail purchaser or put in use prior to sale at retail, whichever date occurs first, and ends at the time or mileage/kilometer limits listed in Table 34, the WARRANTY PERIOD chart.

*LIMITED WARRANTY ON NEW DETROIT DIESEL MBE 900 ENGINES USED IN UNIMOG APPLICATIONS*

<b>Warranty Period</b>					
<b>Item</b>	<b>Warranty Limitations (Whichever Occurs First)</b>			<b>Repair Charges to be Paid by Owner</b>	
	<b>Months</b>	<b>Hours</b>	<b>Miles/ Kilometers</b>	<b>Parts</b>	<b>Labor</b>
Engine	24	Unlimited	Unlimited	No Charge	No Charge
Accessories	24	Unlimited	Unlimited	No Charge	No Charge

**Table 34 Warranty Period Chart — UNIMOG Applications**

**Like Replacement Engine**

Engine(s) supplied by DDC as a replacement for an engine still under warranty will assume the identity of the engine being replaced and be entitled to the remaining warranty coverage.

**Service Supplies**

The cost of service supplies such as coolant, oil and filters which are not reusable due to needed warranty repairs is covered by this warranty.

**Engine Removal and Reinstallation**

Reasonable labor costs for engine removal and reinstallation, when necessary to make a warranty repair, are covered by this warranty.

**This Warranty Does Not Cover:**

**Repairs Due to Accidents, Misuse, Storage Damage, Negligence or Certain Modifications**

Repairs due to an accident, misuse, misapplication, storage damage, negligence or modification exceeding DDC specifications are not covered by this warranty.



## **Maintenance**

DDC is not responsible for the cost of maintenance or repairs due to lack of performance of required maintenance services as recommended by DDC, or the failure to use fuel, oil, lubricants and coolant meeting DDC-recommended specifications. Performance of the required maintenance and use of proper fuel, oil, lubricants and coolant are the responsibility of the owner.

## **Incidental or Consequential Damages**

Detroit Diesel Corporation is not responsible for incidental or consequential costs or expenses which the owner may incur as a result of a malfunction or failure covered by this warranty, such as communication expenses, meals, lodging, overtime, towing, loss of use of the engine or vehicle ("downtime"), loss of time, inconvenience, cargo loss or damage, and other similar costs and expenses.

## **Other Limitations**

Performance of REPAIRS is the exclusive Owner's remedy under this warranty. Detroit Diesel Corporation does not authorize any person to assume or create for it any other obligation or liability in connection with the engine or the accessories.

THIS WARRANTY AND THE EMISSIONS CONTROL WARRANTY ARE THE ONLY WARRANTIES APPLICABLE TO THE ENGINE AS USED IN UNIMOG APPLICATIONS. DETROIT DIESEL CORPORATION MAKES NO OTHER WARRANTIES EXPRESS OR IMPLIED, INCLUDING ANY IMPLIED WARRANTY OF MERCHANTABILITY OR FITNESS FOR A PARTICULAR PURPOSE. DETROIT DIESEL CORPORATION SHALL NOT BE LIABLE FOR ANY INCIDENTAL OR CONSEQUENTIAL DAMAGES AS DESCRIBED ABOVE.

Some states do not allow the limitation of how long this warranty may last or the limitation or exclusion of incidental or consequential damages, so the above may not apply to you. This warranty gives you specific legal rights, and you may also have other rights which may vary from state to state.